



# Valves

American Standard

# More than 50 years of Foundry Experience

## Company Profile

Jinan Meide Casting Co. Ltd. was established in 1962. In the past decades, Jinan Meide has seized each opportunity to consolidate its strength, and has finally developed into what it is today, a large-scale enterprise group with advanced technology, equipment and strong comprehensive strength, known for its complete range of products, large producing capacity, high quality and strong R&D strength. The company owns altogether one main factory, three branch factories, an independent accounting steel pipe company, and a science & technology park.

The company is the largest manufacturer in the fitting industry with the most complete range of products, supplying malleable iron fittings, grooved fittings, grooved couplings, valves, cast iron fittings, ductile iron fittings, steel pipe nipples and couplings, stainless steel nipples, brass pipe nipples, cast bronze fittings, steel pipes, pipe hangers and supports, electric fittings, etc.

Over 50 years, Jinan Meide has been a trusted name in piping solutions by offering high-quality products, service and support to the PVF industry continuously. We provide expertise and product solutions for a wide range of applications, plumbing, mechanical, industrial, air-conditioning and refrigeration, mining, oil, gas, fire protection, equipment and power system. Many of the company's application technology are advanced in the world, with more than 20 patents registered each year, and the company has presided over and participated in the drafting of many important national standards of the industry.

We organize the whole production process in accordance with ISO 9001 and ISO 14001. It has also the most complete certificates in the PVF industry, including UL/FM/NSF of US, CRN/cUL of Canada, DVGW/TUV/CE/VdS of Germany, BSI/LPCB of UK, SII of Israel, JIS of Japan, ABNT of Brazil, GOST-R of Russia, CNBOP of Poland, KS of South Korea, TSE of Turkey, PSB of Singapore, SIRIM of Malaysia, SABS of South Africa etc. The products are well distributed in more than 130 countries and regions.

As an industry leader and key high-tech enterprise of the national torch plan, the company attaches great importance to environmental protection, energy-saving and emission-reduction. US-EEC recognizes MECH brand malleable iron pipe fittings as "the product to promote for the technology exchange of environmental protection". Protecting the environment is the duty of the company.

Customer satisfaction has always been the company's top objective, and we constantly stick to the principle: to provide customers with a value-added solution rather than simply delivering products.



# Company History

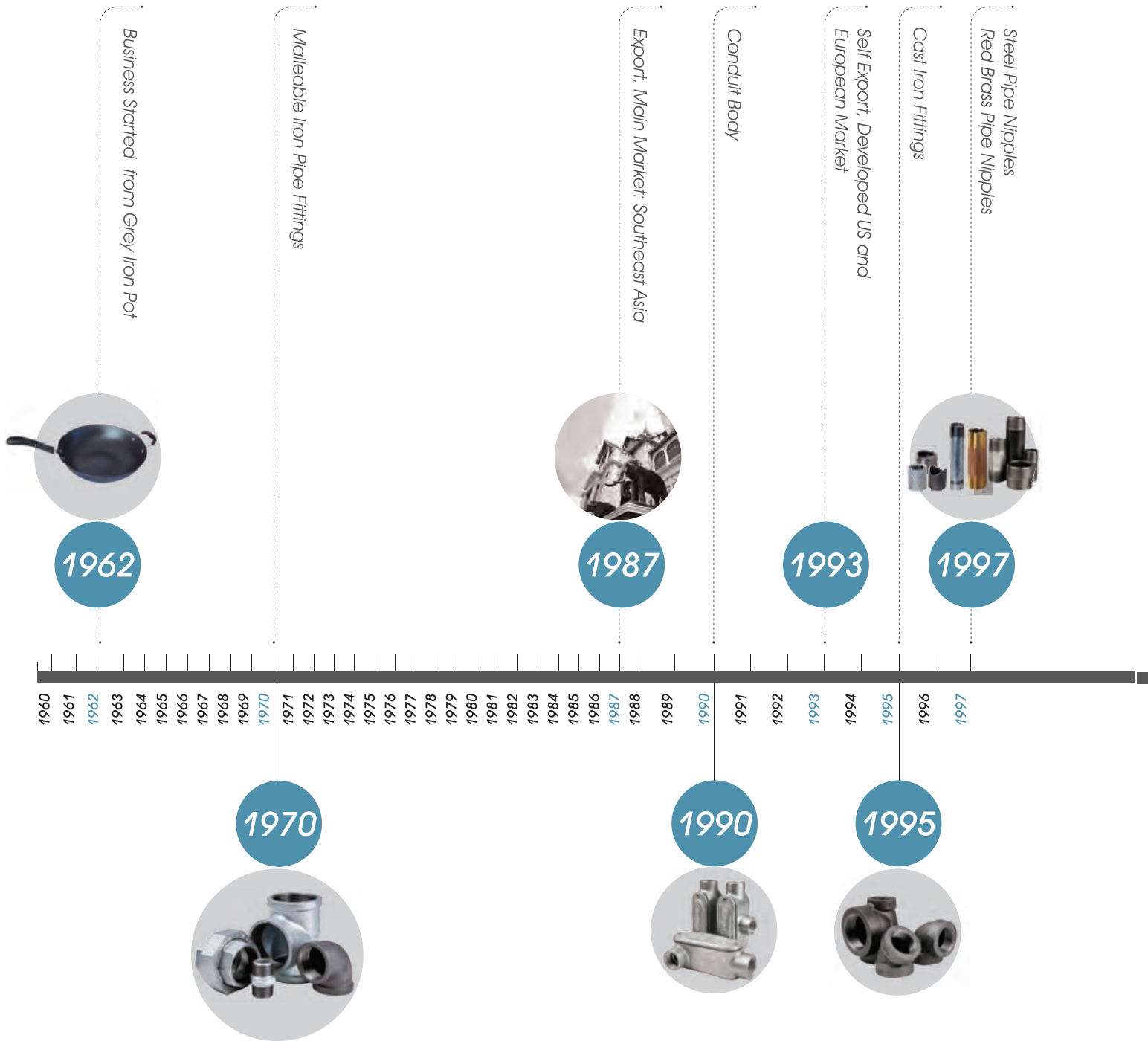

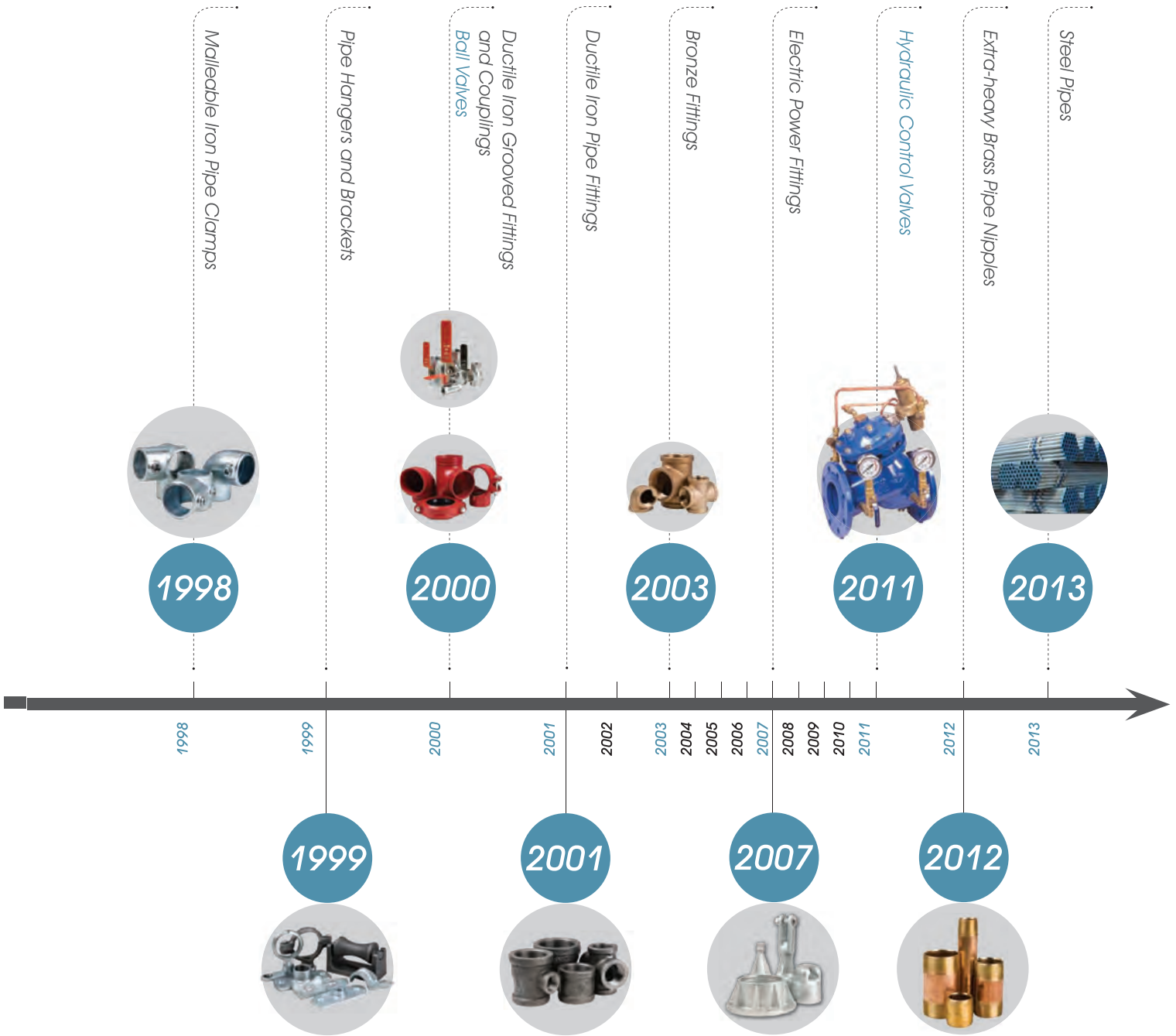

## State of the Art Equipment

High precision equipment is quality assurance. Jinan Meide's 6 factories are all equipped with the most advanced facilities and equipment in the industry. The main production facilities include Sinto automatic molding line, Tokyu automatic molding line, Chinese 416 automatic vertical molding line, automatic molding sand mixers, cupola furnaces, electric furnaces, water-cooled longevous cupola furnaces, CNC vertical machining centers, CNC machines, NC vertical lathes, radial drills, Jinan Meide proprietary automatic machines, hot-dipped galvanization line, automatic box sealing line, stereoscopic warehouse and so on.



Pattern



Tokyu AMF-111055



Pouring





Core Making



Sand Mulling



Melting



Sinto FCMX



Machining



Epoxy Coating



Assembling



Warehouse

## Reliable Quality Assurance

Jinan Meide is honored as the National enterprise technical center and is capable and qualified to conduct full series of tests and inspections including chemical checking, etc.

Inspection facilities include: spectrometer, carbon sulfur analyzer, metallurgical microscope, tensile strength testing equipment, pressure testing equipment, adhesive force testing equipment, CMM, hardness tester, etc.

From incoming inspection to finished product, quality is checked and monitored in the whole process. Each step of the manufacturing process is carefully documented, regularly reviewed for revision control and updating standard. Quality procedures are constantly monitored and updated to assure that only the highest and most consistent quality products are supplied to our valued customers.



Metallurgical Microscope



R & D







CMM

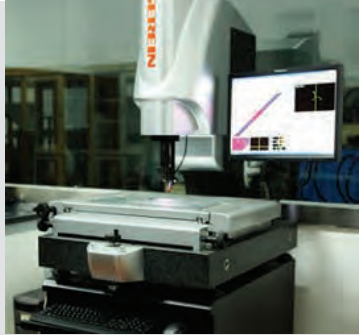

Projector



Valve Pressure Testing Machine (Horizontal)



Valve Pressure Testing Machine (Vertical)



Endurance Test Machine



Valve Pressure Testing Machine (Horizontal)







# Resilient Wedge Gate Valve

**Statement:**

Gate valves serve to cut the medium flow in the piping system, widely used in the field of potable water, water supply and drainage, sewage disposal, irrigation, air conditioning, fire protection as well as chemical and energy industry.

**Features:**

1. Material:

Ductile Iron ASTM A536, 65-45-12  
Body, bonnet, wedge, handwheel and operating nut are all produced in ductile iron material which provides guarantee for high strength and good corrosion resistance.

2. Triple O-ring Stem Seals

The lower O-ring isolates the stem thrust collar bearing area from the waterway. The upper two O-rings can easily be replaced in the line while the valve is under pressure in the open position.

3. Stainless Steel Stem, Brass Thrust Collar and Bronze Wedge Nut

This life-tested MEIDE design has repeatedly proven its superior strength and abrasive resistance.

4. Fusion Bonded Epoxy Coating

Fusion bonded epoxy coating in accordance with ANSI/AWWA C550 for both interior and exterior surface which provides reliable corrosion resistance.

5. Long Service Life with Resilient Seat Cycling Test 1,000 times

The Valve has been subjected to 1,000 cycles of operation at a maximum rate of 6 cycles of operation per minute from fully closed to fully open and from fully open to fully closed positions under cycled hydrostatic pressure.



- Body, Bonnet, Wedge & Operating Nut in Ductile Iron
- Triple O-ring Stem Seals
- Stainless Steel Stem and Brass Thrust Collar
- Bronze Alloy Wedge Nut
- Fusion Bonded Epoxy Coating



XZ41X  
Flanged Resilient OS&Y  
Gate Valve  
Page 11



XZ81X  
Grooved Resilient OS&Y  
Gate Valve  
Page 12



XZ51X  
Flanged x Grooved Resilient OS&Y  
Gate Valve  
Page 13



Z45XC  
Flanged Resilient NRS  
Gate Valve  
Page 14



Z45XC-2  
Flanged Resilient NRS  
Gate Valve with Post Flange  
Page 15



Z85X  
Grooved Resilient NRS  
Gate Valve  
Page 16



Z55X  
Flanged x Grooved Resilient NRS  
Gate Valve  
Page 17



IP  
Vertical Indicator Post  
Page 18



WP  
Wall Indicator Post  
Page 19

## Flanged Resilient OS&Y Gate Valve (XZ41X), UL/FM Approved



XZ41X

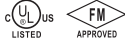

- Connection Ends: Flange to ASME B16.1 CL 125
- Working Pressure: 300PSI  
200PSI and 250PSI available upon request
- Temperature Range: 0°C - 80°C
- Coating: Fusion Bonded Epoxy Coating Complies with ANSI/ AWWA C550



XZ41X-1

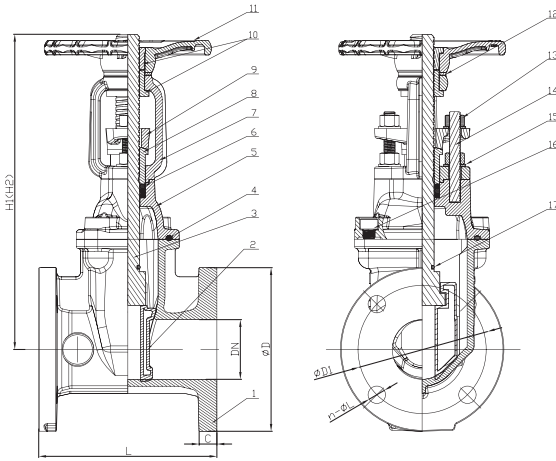

### MATERIAL SPECIFICATION

Part No.	Part	Standard Specification	Options
1	Valve Body	ASTM A536, 65-45-12	
2	Resilient Wedge Disc	ASTM A536, 65-45-12+EPDM	
3	Stem	ANSI 420	AISI 304, AISI 316, AISI 431, Al-bronze
4	Bonnet Gasket	EPDM	
5	Bonnet	ASTM A536, 65-45-12	
6	Stem Packing	EPDM	
7	Yoke	ASTM A536, 65-45-12	
8	Stem Bushing	Brass Hpb59-1	
9	Gland	ASTM A536, 65-45-12	
10	Stem Nut	Brass Hpb59-1	Bronze ZQSn5-5-5
11	Handwheel	ASTM A536, 65-45-12	Pressed Steel
12	Washer	Brass Hpb59-1	
13	Gland Nut	Carbon Steel Zinc Plated	AISI 304, AISI 316
14	Stud	Carbon Steel Zinc Plated	AISI 304, AISI 316
15	Flat Washer	Carbon Steel Zinc Plated	AISI 304, AISI 316
16	Nut	Carbon Steel Zinc Plated	AISI 304, AISI 316
17	O-Ring	EPDM	NBR

Note: For special material request other than standard specification, please indicate clearly on the inquiry or order list.

DN		Dimensions(mm)						
Inch	mm	L	H1(Close)	H2(Open)	D	D1	C	n-ΦL
2"	50	178	348	400	152	120.7	16.0	4-Φ19.1
2.5"	65	190	373	440	178	139.7	17.5	4-Φ19.1
3"	80	203	408	490	191	152.4	19.1	4-Φ19.1
4"	100	229	471	573	229	190.5	19.1	8-Φ19.1
5"	125	254	541	665	254	215.9	19.1	8-Φ22.2
6"	150	267	601	755	279	241.3	19.1	8-Φ22.2
8"	200	292	774	975	343	298.5	22.2	8-Φ22.2
10"	250	330	939	1193	406	362.0	23.8	12-Φ25.4
12"	300	356	1065	1370	483	431.8	25.4	12-Φ25.4

Grooved Resilient OS&Y  
Gate Valve (XZ81X),  
UL/FM Approved



XZ81X



- Connection Ends: Groove to AWWA C606
- Working Pressure: 300PSI  
200PSI and 250PSI available upon request
- Temperature Range: 0°C- 80°C
- Coating: Fusion Bonded Epoxy Coating in accordance with ANSI/AWWA C550 or painting upon request

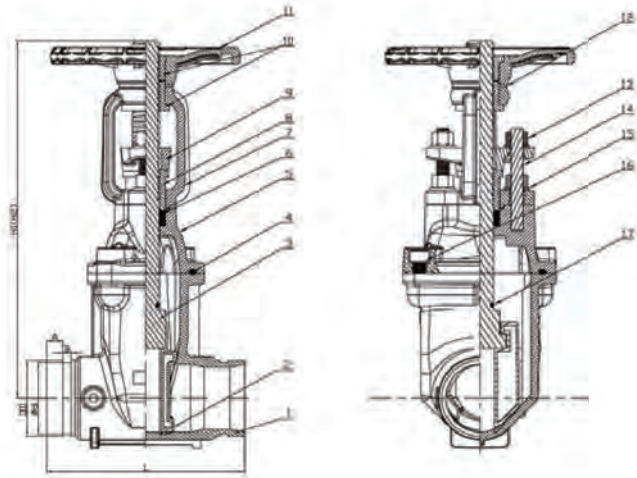

MATERIAL SPECIFICATION

Part No.	Part	Standard Specification	Options
1	Valve Body	ASTM A536, 65-45-12	
2	Resilient Wedge Disc	ASTM A536, 65-45-12+EPDM	
3	Stem	AISI 420	AISI 304, AISI 316, AISI 431, Al-bronze
4	Bonnet Gasket	EPDM	NBR
5	Bonnet	ASTM A536, 65-45-12	
6	Washer	Brass HPb59-1	
7	Yoke	ASTM A536, 65-45-12	
8	Stem Bushing	Brass HPb59-1	
9	Gland	ASTM A536, 65-45-12	
10	Stem Nut	Brass HPb59-1	Bronze ZQSn5-5-5
11	Handwheel	ASTM A536, 65-45-12	Pressed Steel
12	Washer	Brass HPb59-1	
13	Gland Nut	Carbon Steel Zinc Plated	AISI 304, AISI 316
14	Stud	Carbon Steel Zinc Plated	AISI 304, AISI 316
15	Flat Washer	Carbon Steel Zinc Plated	AISI 304, AISI 316
16	Nut	Carbon Steel Zinc Plated	AISI 304, AISI 316
17	O-Ring	EPDM	NBR

Note: For special material request other than standard specification, please indicate clearly on the inquiry or order list.

DN		Dimensions(mm)						
Inch	mm	L	H1(Close)	H2(Open)	OD	d	A	B
2"	50	178	348	400	60.3	57.15	15.88	7.92
2.5"	65	190	373	440	73	69.09	15.88	7.92
3"	80	203	408	490	88.9	84.94	15.88	7.92
4"	100	229	471	573	114.3	110.08	15.88	9.52
5"	125	254	541	665	141.3	137.03	15.88	9.52
6"	150	267	601	755	168.3	163.96	15.88	9.52
8"	200	292	774	975	219.1	214.4	19.05	11.13
10"	250	330	1029	1283	273	268.28	19.05	12.7
12"	300	356	1065	1370	323.9	318.29	19.05	12.7

Flanged x Grooved  
Resilient OS&Y Gate Valve (XZ51X),  
UL/FM Approved

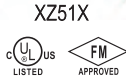

- Connection Ends: Flange to ASME B16.1 CL 125  
Groove to AWWA C606
- Working Pressure: 300PSI  
200PSI and 250PSI available upon request
- Temperature Range: 0°C- 80°C
- Coating: Fusion Bonded Epoxy Coating Complies with  
ANSI/AWWA C550

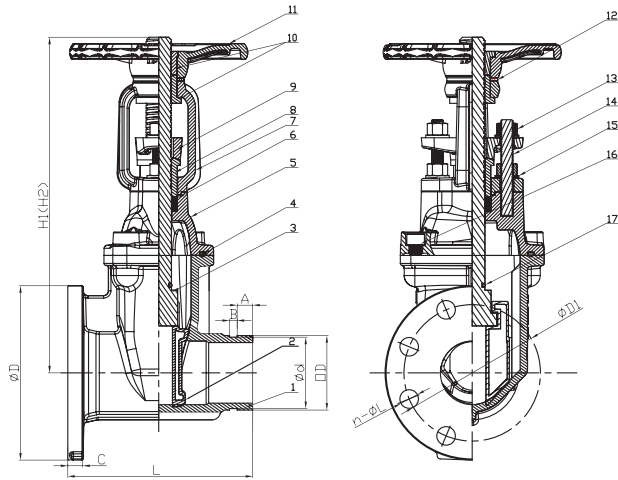

MATERIAL SPECIFICATION

Part No.	Part	Standard Specification	Options
1	Valve Body	ASTM A536, 65-45-12	
2	Resilient Wedge Disc	ASTM A536, 65-45-12+EPDM	
3	Stem	AISI 420	AISI 304, AISI 316, AISI 431, Al-bronze
4	Bonnet Gasket	EPDM	
5	Bonnet	ASTM A536, 65-45-12	
6	Stem Packing	EPDM	
7	Yoke	ASTM A536, 65-45-12	
8	Stem Bushing	Brass Hpb59-1	
9	Gland	ASTM A536, 65-45-12	
10	Stem Nut	Brass Hpb59-1	Bronze ZQSn5-5-5
11	Handwheel	ASTM A536, 65-45-12	Pressed Steel
12	Washer	Brass Hpb59-1	
13	Gland Nut	Carbon Steel Zinc Plated	AISI 304, AISI 316
14	Stud	Carbon Steel Zinc Plated	AISI 304, AISI 316
15	Flat Washer	Carbon Steel Zinc Plated	AISI 304, AISI 316
16	Bolt	Carbon Steel Zinc Plated	AISI 304, AISI 316
17	O-Ring	EPDM	NBR

Note: For special material request other than standard specification, please indicate clearly on the inquiry or order list.

DN		Dimensions(mm)									
Inch	mm	L	H1(Close)	H2(Open)	D	D1	C	n-ΦL	OD	d	A
2"	50	178	348	400	152	120.7	16.0	4-Φ19.1	60.3	57.15	15.88
2.5"	65	190	373	440	178	139.7	17.5	4-Φ19.1	73.0	69.09	15.88
3"	80	203	408	490	191	152.4	19.1	4-Φ19.1	88.9	84.94	15.88
4"	100	229	471	573	229	190.5	19.1	8-Φ19.1	114.3	110.08	15.88
5"	125	254	541	665	254	215.9	19.1	8-Φ22.2	141.3	137.03	15.88
6"	150	267	601	755	279	241.3	19.1	8-Φ22.2	168.3	163.96	15.88
8"	200	292	774	975	343	298.5	22.2	8-Φ22.2	219.1	214.4	19.05
10"	250	330	1029	1283	406	362.0	23.8	12-Φ25.4	273.0	268.28	19.05
12"	300	356	1065	1370	483	431.8	25.4	12-Φ25.4	323.9	318.29	19.05

## Flanged Resilient NRS Gate Valve (Z45XC), UL/FM Approved



Z45XC



- Connection Ends: Flange to ASME B16.1 CL 125
- Working Pressure: 300PSI  
200PSI and 250PSI available upon request
- Temperature Range: 0°C - 80°C
- Coating: Fusion Bonded Epoxy Coating in accordance with ANSI/AWWA C550



Z45X

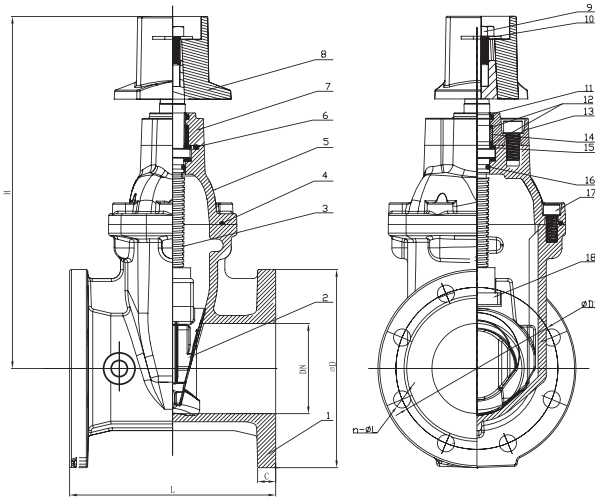

### MATERIAL SPECIFICATION

Part No.	Part	Standard Specification	Options
1	Valve Body	ASTM A536, 65-45-12	
2	Resilient Wedge Disc	ASTM A536, 65-45-12+EPDM	
3	Stem	AISI 431	AISI 304, AISI 316, AISI 420, Al-bronze
4	Bonnet Gasket	EPDM	NBR
5	Bonnet	ASTM A536, 65-45-12	
6	O-Ring	NBR	EPDM
7	Gland	ASTM A536, 65-45-12	
8	Stem Cap	ASTM A536, 65-45-12	
9	Bolt	Carbon Steel Zinc Plated	AISI 304, AISI 316
10	Flat Washer	Carbon Steel Zinc Plated	AISI 304, AISI 316
11	Ring Wiper	EPDM	NBR
12	O-Ring	NBR	EPDM
13	Nut	Carbon Steel Zinc Plated	AISI 304, AISI 316
14	Axis Guide	Brass HPb59-1	
15	Washer	Brass HPb59-1	
16	O-Ring	NBR	EPDM
17	Nut	Carbon Steel Zinc Plated	AISI 304, AISI 316
18	Wedge Nut	Brass HPb59-1	Bronze ZQSn5-5-5

Note: For special material request other than standard specification, please indicate clearly on the inquiry or order list.

DN		Dimensions(mm)						
Inch	mm	L	H(Z45X)	H(Z45XC)	D	D1	C	n-ΦL
2"	50	178	254	278	152	120.7	16	4-Φ19.1
2.5"	65	190	275	300	178	139.7	17.5	4-Φ19.1
3"	80	203	301	321	191	152.4	19.1	4-Φ19.1
4"	100	229	355	375	229	190.5	19.1	8-Φ19.1
5"	125	254	393	415	254	215.9	19.1	8-Φ22.2
6"	150	267	448	455	279	241.3	19.1	8-Φ22.2
8"	200	292	548	565	343	298.5	22.2	8-Φ22.2
10"	250	330	626	636	406	362	23.8	12-Φ25.4
12"	300	356	722	731	483	431.8	25.4	12-Φ25.4



## Flanged Resilient NRS Gate Valve with Post Flange (Z45XC-2), UL Listed



Z45XC-2



- Connection Ends: Flange to ASME B16.1 CL 125
- Working Pressure: 300PSI  
200PSI and 250PSI available upon request
- Temperature Range: 0°C- 80°C
- Coating: Fusion Bonded Epoxy Coating in accordance with ANSI/AWWA C550



Z35XC-2

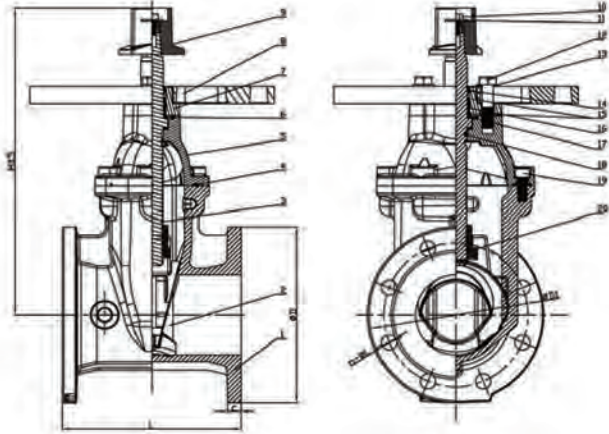

### MATERIAL SPECIFICATION

Part No.	Part	Standard Specification	Options
1	Valve Body	ASTM A536, 65-45-12	
2	Resilient Wedge Disc	ASTM A536, 65-45-12+EPDM	
3	Stem	AISI 431	AISI 304, AISI 316, AISI 420, Al-bronze
4	Bonnet Gasket	EPDM	NBR
5	Bonnet	ASTM A536, 65-45-12	
6	O-Ring	NBR	EPDM
7	Gland	ASTM A536, 65-45-12	
8	Post Flange	ASTM A536, 65-45-12	
9	Square Operating Nut	ASTM A536, 65-45-12	
10	Bolt	Carbon Steel Zinc Plated	AISI 304, AISI 316
11	Flat Washer	Carbon Steel Zinc Plated	AISI 304, AISI 316
12	Nut	Carbon Steel Zinc Plated	AISI 304, AISI 316
13	Flat Washer	Carbon Steel Zinc Plated	AISI 304, AISI 316
14	Ring Wiper	EPDM	NBR
15	O-Ring	NBR	EPDM
16	Axis Guide	Brass Hpb59-1	
17	Washer	Brass Hpb59-1	
18	O-Ring	NBR	EPDM
19	Nut	Carbon Steel Zinc Plated	AISI 304, AISI 316
20	Wedge Nut	Brass Hpb59-1	Bronze ZQSn5-5-5

Note: For special material request other than standard specification, please indicate clearly on the inquiry or order list.

DN		Dimensions(mm)					
Inch	mm	L	H	D	D1	C	n-ΦL
4"	100	229	395	229	190.5	19.1	8-Φ19.1
5"	125	254	432	254	215.9	19.1	8-Φ22.2
6"	150	267	475	279	241.3	19.1	8-Φ22.2
8"	200	292	585	343	298.5	22.2	8-Φ22.2
10"	250	330	656	406	362	23.8	12-Φ25.4
12"	300	356	751	483	431.8	25.4	12-Φ25.4

Grooved Resilient NRS  
Gate Valve (Z85X),  
UL/FM Approved



Z85X

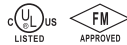

- Connection Ends: Groove to AWWA C606
- Working Pressure: 300PSI  
200PSI and 250PSI available upon request
- Temperature Range: 0°C- 80°C
- Coating: Fusion Bonded Epoxy Coating in accordance with ANSI/AWWA C550 or painting upon request

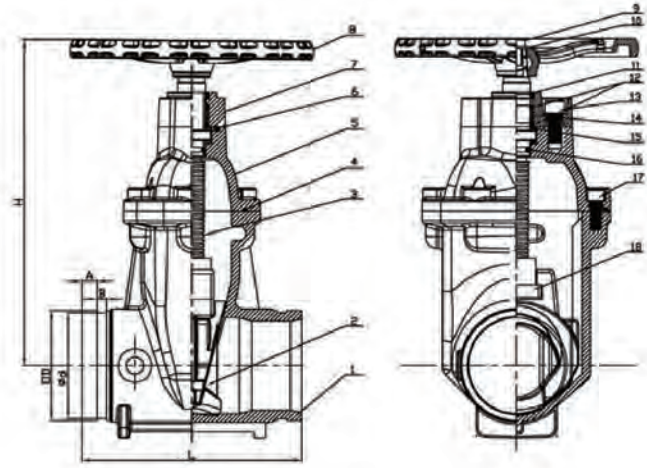

MATERIAL SPECIFICATION

Part No.	Part	Standard Specification	Options
1	Valve Body	ASTM A536, 65-45-12	
2	Resilient Wedge Disc	ASTM A536, 65-45-12+EPDM	
3	Stem	AISI 431	AISI 304, AISI 316, AISI 420, Al-bronze
4	Bonnet Gasket	EPDM	NBR
5	Bonnet	ASTM A536,65-45-12	
6	O-Ring	NBR	EPDM
7	Gland	ASTM A536,65-45-12	
8	Handwheel	ASTM A536,65-45-12	Pressed Steel
9	Bolt	Carbon Steel Zinc Plated	AISI 304, AISI 316
10	Flat Washer	Carbon Steel Zinc Plated	AISI 304, AISI 316
11	Ring Wiper	EPDM	NBR
12	O-Ring	NBR	EPDM
13	Nut	Carbon Steel Zinc Plated	AISI 304, AISI 316
14	Axis Guide	Brass HPb59-1	
15	Washer	Brass HPb59-1	
16	O-Ring	NBR	EPDM
17	Nut	Carbon Steel Zinc Plated	AISI 304, AISI 316
18	Wedge Nut	Brass HPb59-1	Bronze ZQSn5-5-5

Note: For special material request other than standard specification, please indicate clearly on the inquiry or order list.

DN		Dimensions(mm)					
Inch	mm	L	H	OD	d	A	B
2"	50	178	254	60.3	57.15	15.88	7.92
2.5"	65	190	275	73	69.09	15.88	7.92
3"	80	203	301	88.9	84.94	15.88	7.92
4"	100	229	355	114.3	110.08	15.88	9.52
5"	125	254	393	141.3	137.03	15.88	9.52
6"	150	267	448	168.3	163.96	15.88	9.52
8"	200	292	548	219.1	214.4	19.05	11.13
10"	250	330	626	273	268.28	19.05	12.7
12"	300	356	722	323.9	318.29	19.05	12.7

Flanged x Grooved  
Resilient NRS Gate Valve (Z55X),  
UL/FM Approved



Z55X

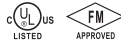

- Connection Ends: Flange to ASME B16.1 CL 125  
Groove to AWWA C606
- Working Pressure: 300PSI  
200PSI and 250PSI available upon request
- Temperature Range: 0°C - 80°C
- Coating: Fusion Bonded Epoxy Coating Complies with  
ANSI/AWWA C550

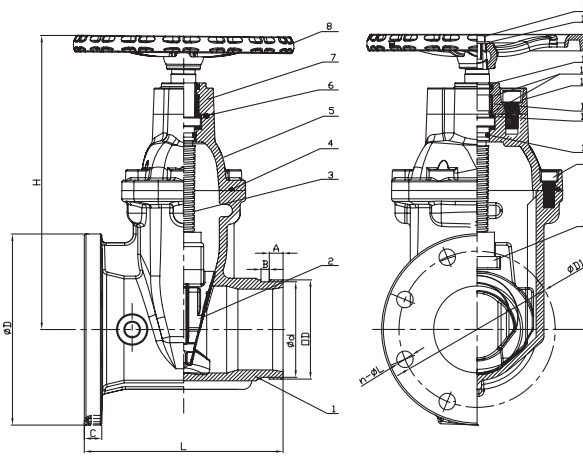

MATERIAL SPECIFICATION

Part No.	Part	Standard Specification	Options
1	Valve Body	ASTM A536, 65-45-12	
2	Resilient Wedge Disc	ASTM A536, 65-45-12+EPDM	
3	Stem	AISI 431	AISI 304, AISI 316, AISI 420, Al-bronze
4	Bonnet Gasket	EPDM	NBR
5	Bonnet	ASTM A536, 65-45-12	
6	O-Ring	NBR	
7	Gland	ASTM A536, 65-45-12	
8	Handwheel	ASTM A536, 65-45-12	
9	Bolt	Carbon Steel Zinc Plated	AISI 304, AISI 316
10	Flat Washer	Carbon Steel Zinc Plated	AISI 304, AISI 316
11	Ring Wiper	EPDM	
12	O-Ring	NBR	
13	Bolt	Carbon Steel Zinc Plated	AISI 304, AISI 316
14	Axis Guide	Brass HPb59-1	
15	Washer	Brass HPb59-1	
16	O-Ring	NBR	
17	Bolt	Carbon Steel Zinc Plated	AISI 304, AISI 316
18	Wedge Nut	Brass HPb59-1	Bronze ZQSn5-5-5

Note: For special material request other than standard specification, please indicate clearly on the inquiry or order list.

DN		Dimensions(mm)								
Inch	mm	L	H	D	D1	C	n-ΦL	OD	d	A
2"	50	178	254	152	120.7	16.0	4-Φ19.1	60.3	57.15	15.88
2.5"	65	190	275	178	139.7	17.5	4-Φ19.1	73.0	69.09	15.88
3"	80	203	301	191	152.4	19.1	4-Φ19.1	88.9	84.94	15.88
4"	100	229	355	229	190.5	19.1	8-Φ19.1	114.3	110.08	15.88
5"	125	254	393	254	215.9	19.1	8-Φ22.2	141.3	137.03	15.88
6"	150	267	448	279	241.3	19.1	8-Φ22.2	168.3	163.96	15.88
8"	200	292	548	343	298.5	22.2	8-Φ22.2	219.1	214.40	19.05
10"	250	330	626	406	362.0	23.8	12-Φ25.4	273.0	268.28	19.05
12"	300	356	722	483	431.8	25.4	12-Φ25.4	323.9	318.29	19.05

## Vertical Indicator Post (IP), UL Listed



IP  
UL LISTED

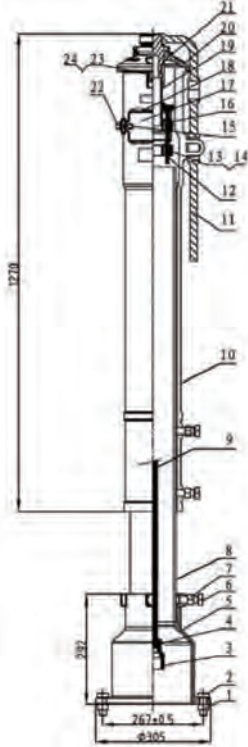

### MATERIAL SPECIFICATION

Part No.	Part	Standard Specification
1	Hex Nut	Carbon Steel Zinc Plated
2	Hex Bolt	Carbon Steel Zinc Plated
3	Socket	ASTM A536, 65-45-12
4	Cotter Pin	AISI 304
5	Base Flange	Cast Iron ASTM A126 Class B
6	Hex Bolt	Carbon Steel Zinc Plated
7	Hex Nut	Carbon Steel Zinc Plated
8	Standpipe	Carbon Steel ASTM A53
9	Stem 1" Square	Carbon Steel AISI 1045
10	Body	Cast Iron ASTM A126 Class B
11	Locking Wrench	ASTM A536, 65-45-12
12	Target Carrier Nut	AISI 304
13	Hex Bolt	Carbon Steel Zinc Plated
14	Hex Nut	Carbon Steel Zinc Plated
15	Hex Bolt	Carbon Steel Zinc Plated
16	Target	Cast Aluminum
17	Window Class	Plexiglass
18	Gasket	PTFE
19	Operating Nut	AISI 304
20	Top Section	Cast Iron ASTM A126 Class B
21	Snap Ring	AISI 1066
22	Plug	Malleable Iron
23	Square Nut	Carbon Steel Zinc Plated
24	Hex Bolt	Carbon Steel Zinc Plated

### Field Adjustment:

1. Remove the Top Section from the top of the Indicator Post assembly;
2. Cut the required stem length and adjust the Standpipe to match up to the ground line;
3. Set the "OPEN" and "SHUT" targets for the appropriate valve size;
4. Reattach the Top Section to the top of the Indicator Post assembly.

- **Statement:**  
Vertical indicator post provides a means to operate a buried or otherwise inaccessible valve and able to indicate the open or shut position of the valve.
- **Coating:**  
Fusion Bonded Epoxy Coating in accordance with ANSI/AWWA C550

## Wall Indicator Post (WP), UL Listed



WP  
UL LISTED

- Statement:  
Wall indicator post provides a means to operate a valve installed behind a wall and able to indicate the open or shut position of the valve.
- Coating:  
Fusion Bonded Epoxy Coating in accordance with ANSI/AWWA C550

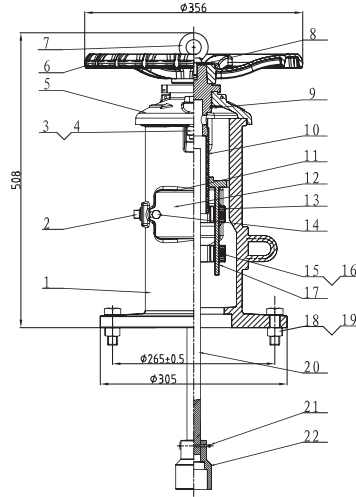

### MATERIAL SPECIFICATION

Part No.	Part	Standard Specification
1	Body	Cast Iron ASTM A126 Class B
2	Plug	Malleable Iron
3	Square Nut	Carbon Steel Zinc Plated
4	Hex Bolt	Carbon Steel Zinc Plated
5	Cover	Cast Iron ASTM A126 Class B
6	Hand wheel	ASTM A536, 65-45-12
7	Eye Bolt	Carbon Steel Zinc Plated
8	Gasket	Carbon Steel Zinc Plated
9	Snap Ring	AISI 1066
10	Operating NUT	AISI 304
11	Gasket	PTFE
12	Window Glass	Plexiglass
13	Target	Cast Aluminum
14	Hex Bolt	Carbon Steel Zinc Plated
15	Hex Bolt	Carbon Steel Zinc Plated
16	Hex Nut	Carbon Steel Zinc Plated
17	Target Carrier Nut	AISI 304
18	Hex Nut	Carbon Steel Zinc Plated
19	Hex Bolt	Carbon Steel Zinc Plated
20	Stem 1" Square	Carbon Steel AISI 1045
21	Cotter Pin	AISI 304
22	Socket	ASTM A536, 65-45-12

Note: For special material request other than standard specification, please indicate clearly on the inquiry or order list;

# Resilient Centerline Butterfly Valve

**• Statement:**

Resilient centerline butterfly valves usually serve to cut off medium flow in the piping system, widely applied in the field of potable water, water supply and drainage, sewage disposal, irrigation, air conditioning, fire protection as well as chemical and energy industry. The design of the butterfly valves, however, makes it also suitable to serve as adjusting valve.

**• Features:**

**1. Material:**

Body is produced in ductile iron material (ASTM A536, 65-45-12) which provides guarantee for high strength and good corrosion resistance.

Different options of the disc and seat, e.g. disc of DI nickel or nylon 11 coated, different series of stainless steel, Al-bronze, seat in EPDM, NBR or Fluororubber, makes it suitable to be applied under different working conditions.

**2. Design:**

Universal flange connection to EN 1092 PN6/10/16, ASME B16.1 CL 125, ASME B16.5 CL 150, GB9113, JIS B2112 10K, AS 2129 Table E, BS 10 Table D/E.

Different options of operation including lever handle, gear box, gear box with tamper switch, electric drive, and pneumatic drive, etc.

Different options of rubber seat including insert rubber seat, rubber vulcanized on valve body and boot rubber seat.

**3. Coating**

Fusion bonded epoxy coating provides reliable corrosion resistance.

To achieve higher corrosion resistance, factory is also able to supply Nylon 11 coated disc. Nylon 11 coating is thermoplastic plant coating approved by USDA with high corrosion resistance and antiseptis which can be applied where there is strict requirement for anti-corrosion.



- Ductile Iron Valve Body
- Stainless Steel Stem
- Fusion Bonded Epoxy Coating
- Disc: DI, Stainless Steel or Al-bronze
- Seat: EPDM/NBR/Fluororubber with backing



XD381X4  
Grooved Butterfly Valve  
with Tamper Switch  
Page 21



D81X4  
Grooved Butterfly Valve  
Page 22



D81X4-BL  
Grooved Butterfly Valve  
Page 23



XD371X4  
Wafer Butterfly Valve  
with Tamper Switch  
Page 24

**Two-Piece Stem Pinless Butterfly Valves Kv Value**

DN		10°	20°	30°	40°	50°	60°	70°	80°	90°
Inch	mm									
2"	50	0.17	4	8	15	23	46	61	99	125
2.5"	65	0.35	7	13	22	36	72	91	151	195
3"	80	0.52	10	19	33	54	108	138	225	281
4"	100	0.69	15	36	63	104	203	264	441	510
5"	125	1.70	39	76	134	216	424	541	865	973
6"	150	2.60	77	125	216	355	692	891	1427	1687
8"	200	3.50	128	216	363	606	1125	1514	2357	2811
10"	250	4.30	201	337	580	995	1860	2379	3720	4325
12"	300	5.20	296	476	865	1384	2682	3503	4325	6488

**One-Piece Stem Pinless Butterfly Valves Kv Value**

DN		10°	20°	30°	40°	50°	60°	70°	80°	90°
Inch	mm									
2"	50	0.05	3	6	13	23	38	61	91	99
2.5"	65	0.09	5	10	22	39	65	103	154	170
3"	80	0.17	8	16	34	61	100	158	238	261
4"	100	0.26	15	31	67	120	199	315	472	519
5"	125	0.43	25	53	115	205	339	536	804	884
6"	150	0.69	29	82	132	222	365	611	998	1366
8"	200	2	48	133	217	365	599	1002	1637	1873
10"	250	3	75	206	333	566	928	1552	2535	2901
12"	300	3	132	361	589	990	1625	2718	4439	5041

## Grooved Butterfly Valve with Tamper Switch (XD381X4)



XD381X4

- Design Standard: MSS SP-67
- Connection Ends: Groove to AWWA C606
- Top Flange Standard: ISO 5211  
Stem drive by keys, parallel or diagonal square or flat head
- Working Pressure: 300PSI  
175PSI, 200PSI and 250PSI available upon request
- Temperature Range: 0°C- 80°C
- Coating: Fusion Bonded Epoxy Coating in accordance with ANSI/AWWA C550 or painting upon request

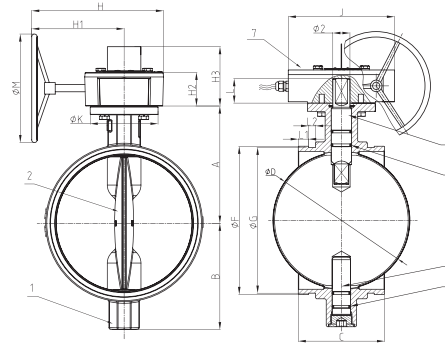

### MATERIAL SPECIFICATION

Part No.	Part	Standard Specification	Options
1	Valve Body	ASTM A536, 65-45-12	
2	Disc	ASTM A536, 65-45-12+EPDM	ASTM A536, 65-45-12+NBR
3	O-Ring	NBR	EPDM
4	Stem	AISI 431	AISI 304, AISI 316, AISI 416, AISI 420
5	O-Ring	NBR	EPDM
6	Stem	AISI 431	AISI 304, AISI 316, AISI 416, AISI 420
7	Signal Gear Box	ASTM A536, 65-45-12	

Note: For special material request other than standard specification, please indicate clearly on the inquiry or order list.

### SWITCH WIRING DIAGRAM

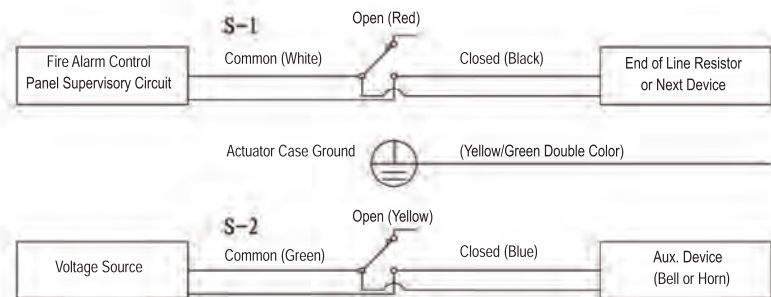

DN		Dimensions(mm)																	
Inch	mm	A	B	C	ΦD	ΦF	ΦG	L1	L2	L	ΦK	H	H1	H2	H3	J	ΦM	Φ2	ISO 5211
2"	50	89	65	81	50.3	60.3	57.15	15.88	7.93	32	90	208	151	65	108	147	150	14	F07
2.5"	65	102	71	97	60.8	73.0	69.09	15.88	7.93	32	90	208	151	65	108	147	150	14	F07
3"	80	109	81	97	76	88.9	84.94	15.88	7.93	32	90	208	151	65	108	147	150	14	F07
4"	100	128	95	116	98.5	114.3	110.08	15.88	9.53	32	90	208	151	65	108	147	150	16	F07
5"	125	141	111	148	122.6	141.3	137.03	15.88	9.53	32	90	208	151	65	108	147	150	16	F07
6"	150	153	133	148	148	168.3	163.96	15.88	9.53	32	90	208	151	65	108	147	150	20	F07
8"	200	184	164	133	199	219.1	214.4	19.05	11.10	45	125	303	239	73	115	190	250	26	F10
10"	250	216	196	159	252	273.1	268.28	19.05	12.70	45	125	303	239	73	115	190	250	26	F10
12"	300	254	226	165	300.5	323.9	318.29	19.05	12.70	45	125	303	229	73	120	190	250	28	F10

Note: Valve must not be installed with disc in full open position. Disc must be partly closed so that no part is protruding beyond end of valve body.

## Grooved Butterfly Valve (D81X4, D381X4)



D81X4

- Design Standard: MSS SP-67
- Connection Ends: Groove to AWWA C606
- Top Flange Standard: ISO 5211  
Stem drive by keys, parallel or diagonal square or flat head
- Working Pressure: 300PSI  
175PSI, 200PSI and 250PSI available upon request
- Temperature Range: 0°C- 80°C
- Coating: Fusion Bonded Epoxy Coating in accordance with ANSI/AWWA C550 or painting upon request

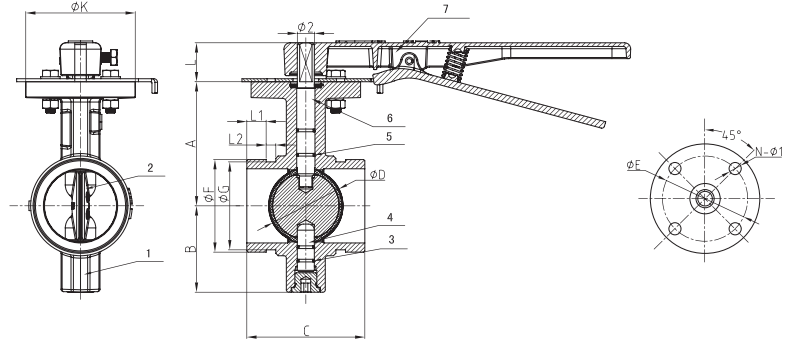

### MATERIAL SPECIFICATION

Part No.	Part	Standard Specification	Options
1	Valve Body	ASTM A536, 65-45-12	
2	Disc	ASTM A536, 65-45-12+EPDM	ASTM A536, 65-45-12+NBR
3	O-Ring	NBR	EPDM
4	Stem	AISI 431	AISI 304, AISI 316, AISI 416, AISI 420
5	O-Ring	NBR	EPDM
6	Stem	AISI 431	AISI 304, AISI 316, AISI 416, AISI 420
7	Lever	ASTM A536, 65-45-12	Aluminum
8	Gear Box	ASTM A536, 65-45-12	

Note: For special material request other than standard specification, please indicate clearly on the inquiry or order list.

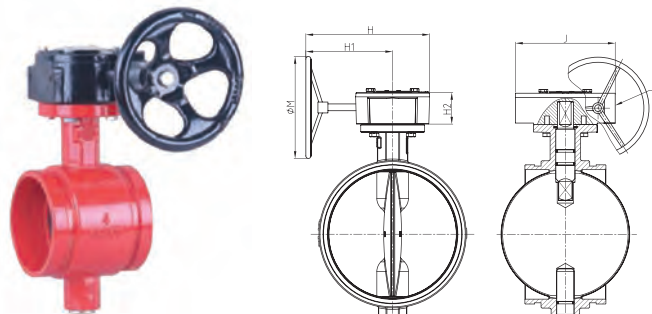

D381X4

DN		Dimensions(mm)																		
Inch	mm	A	B	C	ΦD	ΦF	ΦG	L1	L2	L	ΦK	H	H1	H2	J	ΦM	Φ2	ISO 5211	ΦE	N-Φ1
2"	50	89	65	81	50.3	60.3	57.15	15.88	7.93	32	90	206	158	52	114	150	14	F07	70	4-Φ10
2.5"	65	102	71	97	60.8	73.0	69.09	15.88	7.93	32	90	206	158	52	114	150	14	F07	70	4-Φ10
3"	80	109	81	97	76	88.9	84.94	15.88	7.93	32	90	206	158	52	114	150	14	F07	70	4-Φ10
4"	100	128	95	116	98.5	114.3	110.08	15.88	9.53	32	90	206	158	52	114	150	16	F07	70	4-Φ10
5"	125	141	111	148	122.6	141.3	137.03	15.88	9.53	32	90	206	158	52	114	150	16	F07	70	4-Φ10
6"	150	153	133	148	148	168.3	163.96	15.88	9.53	32	90	206	158	52	114	150	20	F07	70	4-Φ10
8"	200	184	164	133	199	219.1	214.4	19.05	11.10	45	125	310	239	69	167	300	26	F10	102	4-Φ12
10"	250	216	196	159	252	273.1	268.28	19.05	12.70	45	125	310	239	69	167	300	26	F10	102	4-Φ12
12"	300	254	226	165	300.5	323.9	318.29	19.05	12.70	45	125	307	229	73	190	300	28	F10	102	4-Φ12

Note: Valve must not be installed with disc in full open position. Disc must be partly closed so that no part is protruding beyond end of valve body.



## Grooved Butterfly Valve (D81X4-BL, D381X4-BL)



D81X4-BL

- Design Standard: MSS SP-67
- Connection Ends: Groove to AWWA C606
- Top Flange Standard: ISO 5211  
Stem drive by keys, parallel or diagonal square or flat head
- Working Pressure: 300PSI  
175PSI, 200PSI and 250PSI available upon request
- Temperature Range: 0°C - 80°C
- Coating: Fusion Bonded Epoxy Coating in accordance with ANSI/AWWA C550 or painting upon request

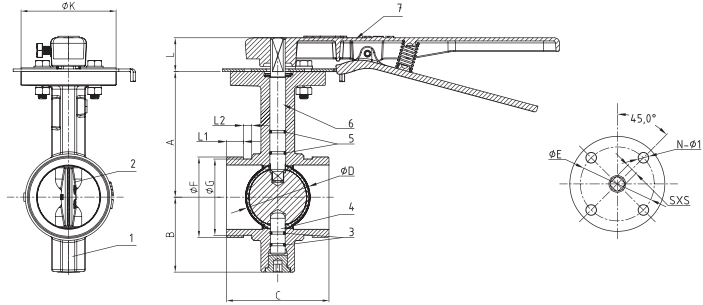

### MATERIAL SPECIFICATION

Part No.	Part	Standard Specification	Options
1	Valve Body	ASTM A536, 65-45-12	
2	Disc	ASTM A536, 65-45-12+EPDM	ASTM A536, 65-45-12+NBR
3	O-Ring	NBR	EPDM
4	Stem	AISI 431	AISI 304, AISI 316, AISI 416, AISI 420
5	O-Ring	NBR	EPDM
6	Stem	AISI 431	AISI 304, AISI 316, AISI 416, AISI 420
7	Lever	ASTM A536, 65-45-12	Aluminum
8	Gear Box	ASTM A536, 65-45-12	

Note: For special material request other than standard specification, please indicate clearly on the inquiry or order list.

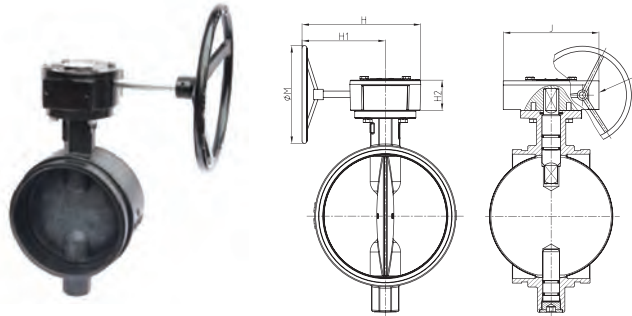

D381X4-BL

DN		Dimensions(mm)																		
Inch	mm	A	B	C	ΦD	ΦF	ΦG	L1	L2	L	ΦK	H	H1	H2	J	ΦM	SXS	ISO 5211	ΦE	N-Φ1
2"	50	100	65	81	50.3	60.3	57.15	15.88	7.93	32	90	206	158	52	114	150	11X11	F07	70	4-Φ10
2.5"	65	115	71	97	60.8	73.0	69.09	15.88	7.93	32	90	206	158	52	114	150	11X11	F07	70	4-Φ10
3"	80	113	81	97	76	88.9	84.94	15.88	7.93	32	90	206	158	52	114	150	11X11	F07	70	4-Φ10
4"	100	145	95	116	98.5	114.3	110.08	15.88	9.53	32	90	206	158	52	114	150	14X14	F07	70	4-Φ10
5"	125	141	111	148	122.6	141.3	137.03	15.88	9.53	32	90	206	158	52	114	150	14X14	F07	70	4-Φ10
6"	150	177	133	148	148	168.3	163.96	15.88	9.53	32	90	206	158	52	114	150	17X17	F07	70	4-Φ10
8"	200	200	164	133	199	219.1	214.4	19.05	11.10	45	125	310	239	69	167	300	17X17	F10	102	4-Φ12
10"	250	280	196	159	252	273.1	268.28	19.05	12.70	45	125	310	239	69	167	300	22X22	F10	102	4-Φ12
12"	300	300	226	165	300.5	323.9	318.29	19.05	12.70	45	125	307	229	73	190	300	22X22	F10	102	4-Φ12

Note: Valve must not be installed with disc in full open position. Disc must be partly closed so that no part is protruding beyond end of valve body.

## Wafer Butterfly Valve with Tamper Switch (XD371X4)



XD371X4

- Design Standard: MSS SP-67
- Connection Ends: ASME B16.1 CL 125, ASME B16.5 CL 150
- Top Flange Standard: ISO 5211  
Stem drive by keys, parallel or diagonal square or flat head
- Working Pressure: 250PSI  
175PSI, 200PSI and 300PSI available upon request
- Temperature Range: 0°C- 80°C
- Coating: Fusion Bonded Epoxy Coating in accordance with ANSI/AWWA C550

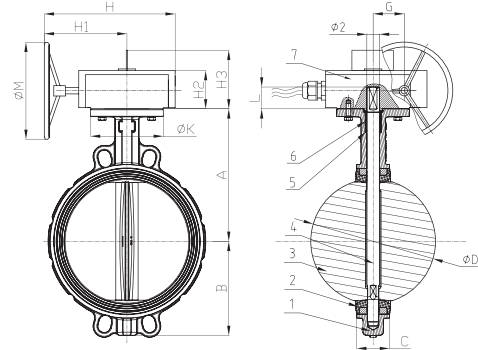

### MATERIAL SPECIFICATION

Part No.	Part	Standard Specification	Options
1	Valve Body	ASTM A536, 65-45-12	
2	Seat	EPDM & Backing	NBR/Fluororubber&Backing EPDM/NBR Vulcanized on Valve Body Soft Seat in EPDM/NBR
3	Disc	ASTM A536, 65-45-12	AISI 304, AISI 316, AL-Bronze C95400
4	Stem	AISI 420, One-Piece Stem Design	AISI 304, AISI 316, AISI 416, AISI 431
5	O-Ring	NBR	EPDM
6	Bushing	PTFE	Nylon 1010
7	Signal Gear Box	ASTM A536, 65-45-12	

Note: For special material request other than standard specification, please indicate clearly on the inquiry or order list.

### SWITCH WIRING DIAGRAM

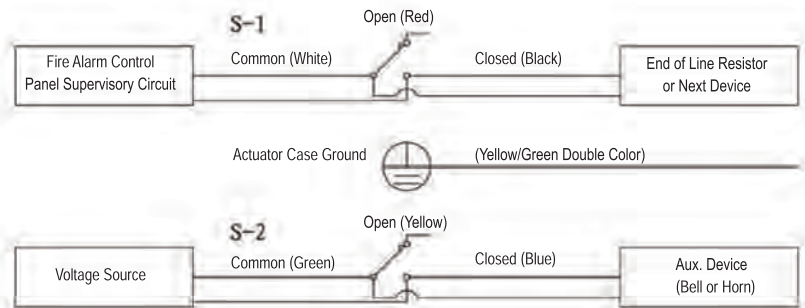

DN		Dimensions(mm)													
Inch	mm	A	B	M	H	H1	H2	H3	K	G	ØD	C	Ø2	L	ISO 5211
2"	50	140.5	64.5	150	208	151	65	108	90	59	53.9	43	14	32	F07
2.5"	65	153	72	150	208	151	65	108	90	59	65.2	46	14	32	F07
3"	80	157.5	86	150	208	151	65	108	90	59	79.7	46	14	32	F07
4"	100	176	100	150	208	151	65	108	90	59	105	52	16	32	F07
5"	125	191	112	150	208	151	65	108	90	59	130	56	16	32	F07
6"	150	202.5	128	150	208	151	65	108	90	59	156	56	20	32	F07
8"	200	243.5	162	250	303	239	73	115	125	77.5	207	60	26	45	F10
10"	250	273	194	250	303	239	73	115	125	77.5	253.3	68	26	45	F10
12"	300	311	223	250	303	229	73	120	125	77.5	301.9	78	28	45	F10

# Check Valve

• **Statement:**

Check valves serve to prevent the backflow of medium in the piping system for protection of important equipments, widely used in the field of potable water, water supply and drainage, sewage disposal, irrigation, air conditioning, fire protection as well as chemical and energy industry.

• **Features:**

1. Material: Ductile Iron ASTM A536, 65-45-12  
Valve body, bonnet, disc are all produced in ductile iron material which provides guarantee for high strength and good corrosion resistance.
2. Fusion Bonded Epoxy Coating  
Fusion bonded epoxy coating in accordance with ANSI/AWWA C550 for both interior and exterior surface which provides reliable corrosion resistance.
3. Small Hydraulic Friction Loss with Reasonable Structure Design

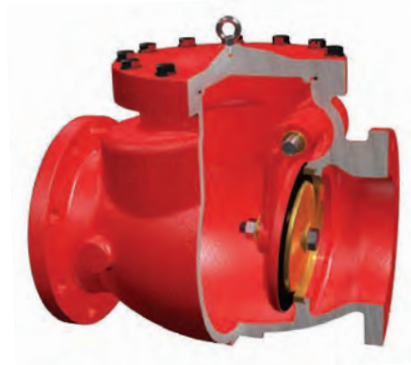

- Body & Bonnet: Ductile Iron
- Disc: D.I.+EPDM or D.I. + Bronze or Stainless Steel Sealing
- Bronze or Stainless Steel Seat
- Fusion Bonded Epoxy Coating

For Fire Sprinkler System



H44X2  
Flanged Resilient Swing  
Check Valve  
Page 26



H84X  
Grooved Resilient Swing  
Check Valve  
Page 27

## Flanged Resilient Swing Check Valve (H44X2), UL/FM Approved



H44X2

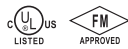

- Connection Ends: Flange to ASME B16.1 CL 125
- Working Pressure: 300PSI  
200PSI and 250PSI available upon request
- Temperature Range: 0°C- 80°C
- Coating: Fusion Bonded Epoxy Coating in accordance with ANSI/AWWA C550

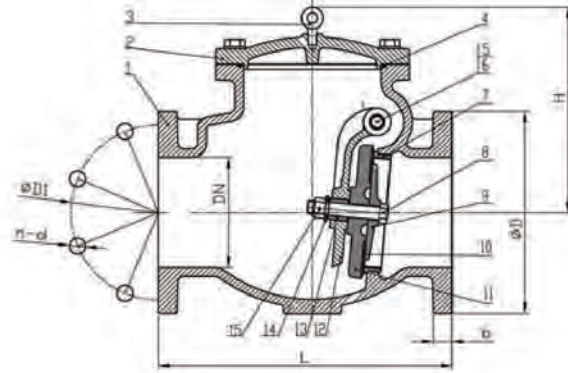

### MATERIAL SPECIFICATION

Part No.	Part	Standard Specification	Options
1	Valve Body	ASTM A536, 65-45-12	
2	Bonnet	ASTM A536, 65-45-12	
3	Eye Bolt	Carbon Steel Zinc Plated	
4	O-Ring	NBR	EPDM
5	Hinge Pin	AISI 304	
6	Hinge Bushing	Brass ASTM B16 C36000/Hpb63-3	
7	Seat Ring	Bronze ASTM B62 C83600/ZQSn5-5-5(Pressed Fit)	AISI 304, AISI 316 Pressed Fit or Threaded
8	Disc Seat Bolt	AISI 304	
9	Retainer Washer	Bronze ASTM B62 C83600/ZQSn5-5-5	
10	Disc Sealing Ring	EPDM	AISI 304, AISI 316, Bronze ASTM B62
11	Disc	ASTM A536, 65-45-12	
12	Clapper Arm	ASTM A536, 65-45-12	
13	Stud Bushing	Brass ASTM B16 C36000/Hpb63-3	
14	O-Ring	NBR	EPDM
15	Nut	AISI 304	AISI 316

Note: For special material request other than standard specification, please indicate clearly on the inquiry or order list.

DN		Dimensions(mm)					
Inch	mm	L	D	D1	b	n-Φd	H
2"	50	203	152	120.5	16	4-Φ19.1	133
2.5"	65	254	178	139.5	17.5	4-Φ19.1	150
3"	80	278	191	152.5	19	4-Φ19.1	243
4"	100	330	229	190.5	24	8-Φ19.1	284
6"	150	406	279	241.5	25.5	8-Φ22.2	290
8"	200	495	343	298.5	28.5	8-Φ22.2	330
10"	250	622	406	362	30.5	12-Φ25.4	350
12"	300	660	483	432	32	12-Φ25.4	376

Grooved Resilient  
Swing Check Valve (H84X),  
UL Listed



H84X



- Connection Ends: Groove to AWWA C606
- Working Pressure: 300PSI  
200PSI and 250PSI available upon request
- Temperature Range: 0°C- 80°C
- Coating: Fusion Bonded Epoxy Coating in accordance with ANSI/AWWA C550 or painting upon request

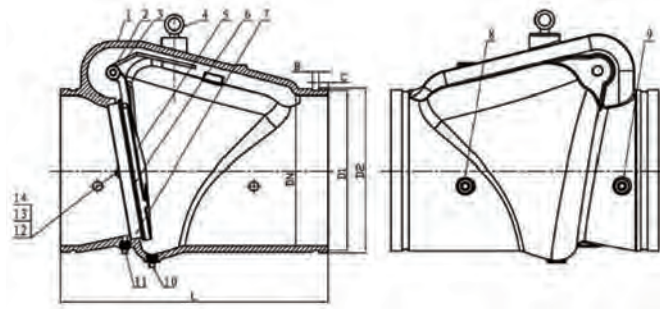

MATERIAL SPECIFICATION

Part No.	Part	Standard Specification	Options
1	Valve Body	ASTM A536, 65-45-12	
2	Hinge Pin	AISI 420	
3	Spring	AISI 304	AISI 316
4	Eye Bolt	Carbon Steel Zinc Plated	
5	Disc	DN50-100 AISI 304 DN150-300 ASTM A536, 65-45-12	AISI 304
6	Disc Sealing Ring	EPDM	
7	Seat Ring	ASTM B62 C83600 (Pressed Fit)	AISI 304, AISI 316 Pressed Fit or Threaded
8	Plug	Malleable Iron Galvanized	Bronze ASTM B584
9	Plug	Malleable Iron Galvanized	Bronze ASTM B584
10	Plug	Malleable Iron Galvanized	Bronze ASTM B584
11	Plug	Malleable Iron Galvanized	Bronze ASTM B584
12	Bolt	AISI 304	AISI 316
13	Washer	AISI 304	AISI 316
14	Nut	AISI 304	AISI 316

Note: For special material request other than standard specification, please indicate clearly on the inquiry or order list.

DN		Dimensions(mm)				
Inch	mm	L	D1	D2	B	C
2"	50	171	57.15	60.3	7.93	15.88
2.5"	65	184	69.09	73	7.93	15.88
3"	80	197	84.94	88.9	7.93	15.88
4"	100	210	110.08	114.3	9.53	15.88
5"	125	248	137.03	141.3	9.53	15.88
6"	150	324	163.96	168.3	9.53	15.88
8"	200	371	214.4	219.1	11.13	19.05
10"	250	457	268.28	273	12.7	19.05
12"	300	535	318.29	323.9	12.7	19.05

## Y-Type Strainer

• **Statement:**

Installed before relief valves, atmospheric valves, hydraulic control valves as well as other equipments, strainers serve to filter out the impurities in the flow medium for protection of valves and equipments in the piping system.

• **Features:**

1. Material: Ductile Iron ASTM A536, 65-45-12  
Valve body and cover are produced in ductile iron material which provides guarantee for high strength and good corrosion resistance.
2. Different Options of Screen Mesh Specification  
Different options of screen mesh specification available as per different service conditions.
3. Fusion Bonded Epoxy Coating  
Fusion bonded epoxy coating in accordance with ANSI/AWWA C550 for both interior and exterior surface which provides reliable corrosion resistance.

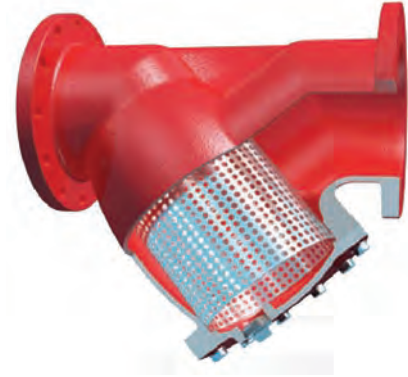

- Ductile Iron Body & Bonnet
- Stainless Steel Screen
- Fusion Bonded Epoxy Coating
- Gasket: EPDM or Graphite + Acanthopore Plate



V4  
Flanged Y-Type Strainer  
Page 29



V8  
Grooved Y-Type Strainer  
Page 30

## Flanged Y-Type Strainer (V4), UL Listed



V4  
UL LISTED

- Connection Ends: Flange to ASME B16.1 CL 125
- Working Pressure: 300PSI  
200PSI and 250PSI available upon request
- Temperature Range: 0°C- 80°C rubber gasket,  
-10°C- 350°C graphite gasket
- Coating: Fusion Bonded Epoxy Coating in accordance with  
ANSI/AWWA C550

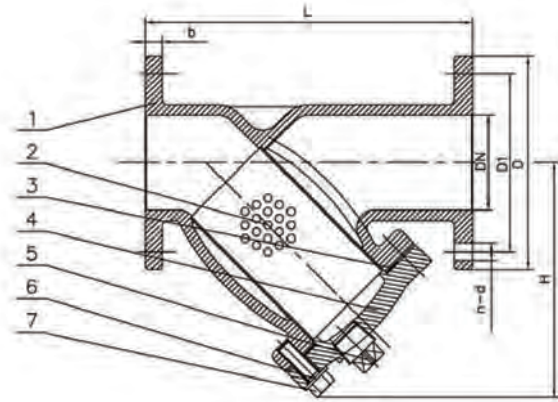

### MATERIAL SPECIFICATION

Part No.	Part	Standard Specification	Options
1	Valve Body	ASTM A536 65-45-12	
2	Screen	AISI 304 (Perforated)	AISI 304, AISI 316 (Perforated, Knitted, Double Screen)
3	Gasket	EPDM	Graphite + Acanthopore Plate
4	Bonnet	ASTM A536 65-45-12	
5	Plug	Malleable Iron Galvanized	Bronze ASTM B584
6	Bolt	Carbon Steel Zinc Plated	AISI 304, AISI 316
7	Flat Washer	Carbon Steel Zinc Plated	AISI 304, AISI 316

### STANDARD SCREEN

DN		Sieve No.	Hole Dia.	Free Flow Area(%)
Inch	mm		mm	%
2"-2.5"	50-65	25	4	48
3"-4"	80-100	19	5	59
5"	125	14	6	63
6"-12"	150-300	13	6.3	64

Note: For special material request other than standard specification, please indicate clearly on the inquiry or order list.

DN		Dimensions(mm)					
Inch	mm	L	D	D1	b	n-Φd	H
2"	50	200	152	120.5	16	4-Φ19.1	155
2.5"	65	254	178	139.5	17.5	4-Φ19.1	165
3"	80	257	191	152.5	19	4-Φ19.1	180
4"	100	308	229	190.5	24	8-Φ19.1	229
5"	125	397	254	216	24	8-Φ22.2	285
6"	150	470	279	241.5	25.5	8-Φ22.2	311
8"	200	549	343	298.5	28.5	8-Φ22.2	394
10"	250	654	406	362	30.5	12-Φ25.4	487
12"	300	759	483	432	32	12-Φ25.4	547

## Grooved Y-Type Strainer (V8), UL Listed



- Connection Ends: Groove to AWWA C606
- Working Pressure: 300PSI  
200PSI and 250PSI available upon request
- Temperature Range: 0°C- 80°C
- Coating: Fusion Bonded Epoxy Coating in accordance with ANSI/AWWA C550 or painting upon request

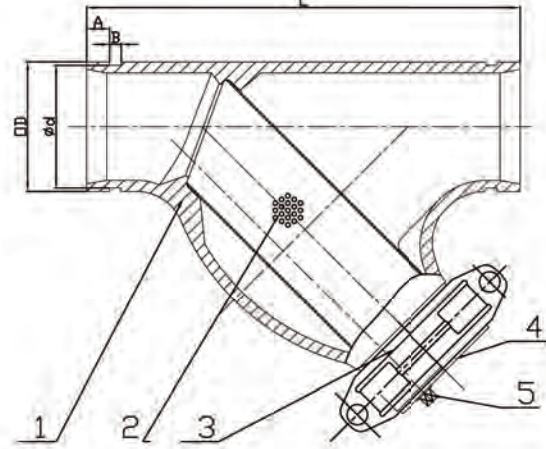

### MATERIAL SPECIFICATION

Part No.	Part	Standard Specification	Options
1	Valve Body	ASTM A536, 65-45-12	
2	Screen	AISI 304	AISI 316
3	Rigid Coupling	ASTM A536, 65-45-12	
4	Cap	ASTM A536, 65-45-12	
5	Plug	Malleable Iron Galvanized	Bronze ASTM B584

### STANDARD SCREEN

DN		Sieve No.	Hole Dia.	Free Flow Area(%)
Inch	mm		mm	%
2"-2.5"	50-65	25	4	48
3"-4"	80-100	18	5	53
5"	125	13	6	58
6"-12"	150-300	12	6.3	56

Note: For special material request other than standard specification, please indicate clearly on the inquiry or order list.

DN		Dimensions(mm)				
Inch	mm	L	OD	d	A	B
2"	50	247.5	60.3	57.15	15.88	7.92
2.5"	65	273	73	69.09	15.88	7.92
3"	80	298.5	88.9	84.94	15.88	7.92
4"	100	362	114.3	110.08	15.88	9.52
5"	125	419	141.3	137.03	15.88	9.52
6"	150	470	168.3	163.96	15.88	9.52
8"	200	609.5	219.1	214.4	19.05	11.13
10"	250	686	273	268.28	19.05	12.7
12"	300	762	323.9	318.29	19.05	12.7



## Water Flow Indicator (ZSJZ)



ZSJZ

- Connection Ends: AWWA C606
- Working Pressure: 300PSI  
200PSI and 250PSI available upon request
- Temperature Range: 0°C - 80°C
- Coating: Fusion Bonded Epoxy Coating in accordance with ANSI/AWWA C550

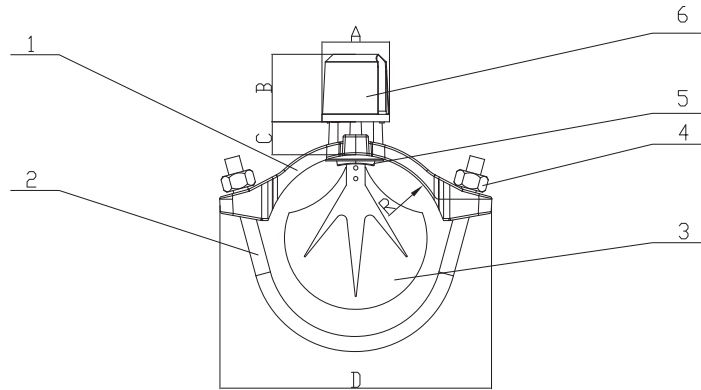

### MATERIAL SPECIFICATION

Part No.	Part	Standard Specification	Options
1	Body	ASTM A536, 65-45-12	
2	Bolt	Carbon Steel Zinc Plated	SS304, SS316
3	Lodicule	Plastic	
4	Nut	Carbon Steel Zinc Plated	SS304, SS316
5	Gasket	EPDM	NBR

Note: For special material request other than standard specification, please indicate clearly on the inquiry or order list.

DN		Dimensions(mm)				
Inch	mm	R	A	B	C	D
2"	50	60.3	62	48	36	120
2.5"	65	73	62	48	31	130
3"	80	88.9	62	48	36.5	145
4"	100	114.3	62	48	30.5	185
5"	125	141.3	62	48	36.5	221.5
6"	150	168.3	62	48	33	254
8"	200	219.1	62	48	36.5	300

## Landing Valve(SN)



SN

- Thread: ISO 7-1
- Working Pressure: 300PSI  
200PSI and 250PSI available upon request
- Temperature Range: 0°C - 80°C
- Coating: Fusion Bonded Epoxy Coating in accordance with ANSI/AWWA C550

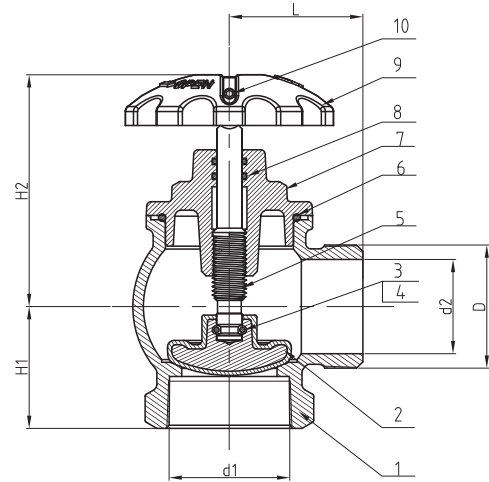

### MATERIAL SPECIFICATION

Part No.	Part	Standard Specification
1	Body	ASTM A536, 65-45-12
2	Disc	ASTM A536, 65-45-12
3	Steel Ball	AISI 304
4	Inner Hex Screw	AISI 304
5	Stem	AISI 420
6	O-Ring	NBR
7	Bonnet	ASTM A536, 65-45-12
8	O-Ring	NBR
9	Handwheel	ABS
10	Screw	AISI 304

DN		Dimensions(mm)					
Inch	mm	H1	H2	L	d1(Rc)	d2	D(R)
2"	50	57.5	109.5	63	2	44.5	2
2.5"	65	71	109.3	71	2 <sup>1/2</sup>	58	2 <sup>1/2</sup>

# Wet Alarm Check Valve

• **Statement:**

The alarm check valve works as a check valve by preventing the reverse flow of water from the system piping to the water supply. The valve is trimmed with a water bypass line, which has an in-line swing check valve. The bypass line allows pressure surges to enter the system and to be trapped above the alarm check valve's clapper without the clapper lifting and causing false alarms.

When a significant flow of water occurs, such as from an open sprinkler, the alarm valve's clapper lifts and allows water to enter the system. Simultaneously, water enters an intermediate chamber, which allows the water to activate an alarm either through a water motor alarm or through a water pressure alarm. These alarms continue to sound until the flow of water is stopped.



For Fire Sprinkler System

DN		Dimensions(mm)	
Inch	mm	OD	Equivalent Length of Pipe (m)
3"	80	88.9	4.9
4"	100	114.3	7.9
6"	150	168.3	9.8
8"	200	219.1	8.2

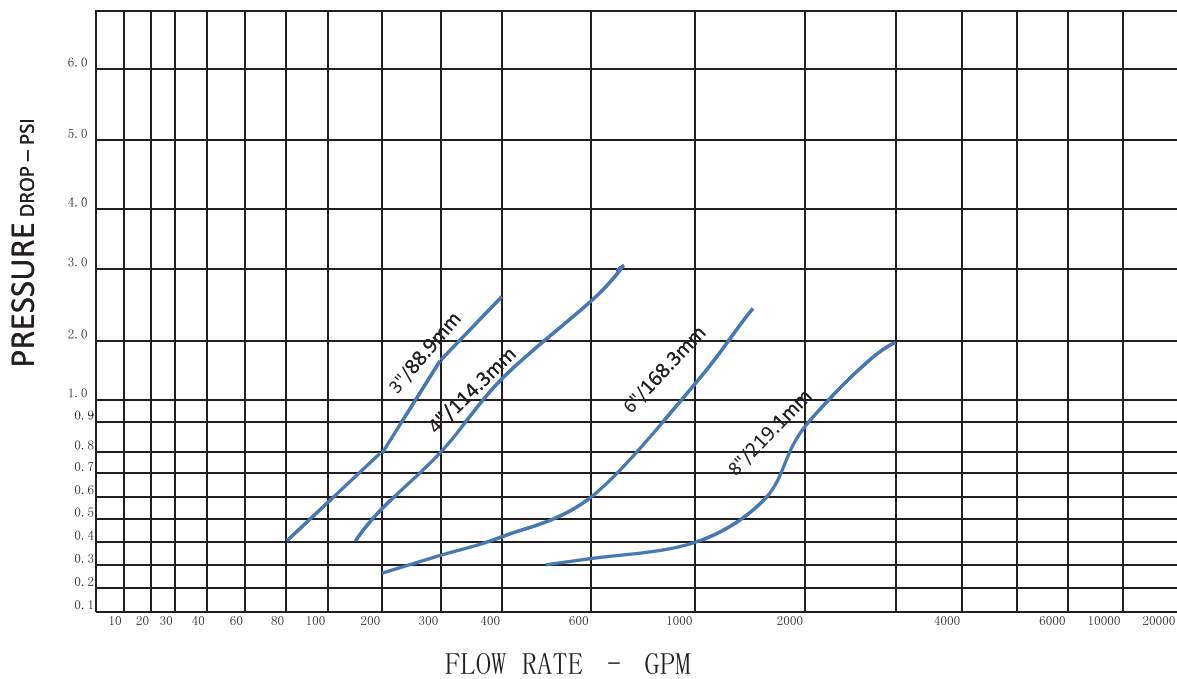

## Wet Alarm Check Valve (ZSFZ)



ZSFZ

- Connection Ends: Groove to AWWA C606
- Working Pressure: 300PSI  
200PSI and 250PSI available upon request
- Temperature Range: 0°C- 80°C
- Coating: Painting or Fusion Bonded Epoxy Coating in accordance with ANSI/AWWA C550

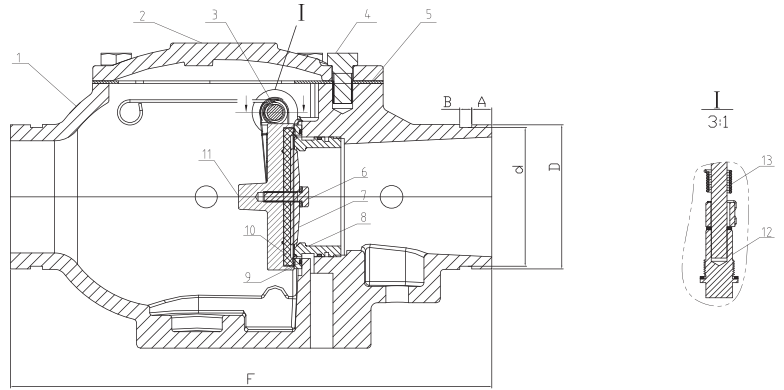

### MATERIAL SPECIFICATION

Part No.	Part	Standard Specification	Options
1	Valve Body	ASTM A536, 65-45-12	
2	Bonnet	ASTM A536, 65-45-12	
3	Pin	AISI 304	AISI 316
4	Hex Bolt	Carbon Steel Zinc Plated	
5	Gasket	NBR	EPDM
6	Hex Bolt	AISI 304	AISI 316
7	Gland	Brass H62	
8	Seat	C83600	
9	O-Ring	NBR	EPDM
10	Gasket	EPDM	
11	Disc	Brass H62	
12	Plug	AISI 304	AISI 316
13	Spring	AISI 321	

Note: For special material request other than standard specification, please indicate clearly on the inquiry or order list.

DN		Dimensions(mm)					
Inch	mm	OD	A	B	Ø d	Ø D	F
3"	80	88.9	15.88	7.93	84.94	88.9	320.3
4"	100	114.3	15.88	9.53	110.08	114.3	382
6"	150	168.3	15.88	9.53	163.96	168.3	406.4
8"	200	219.1	19.05	11.1	214.4	219.1	446

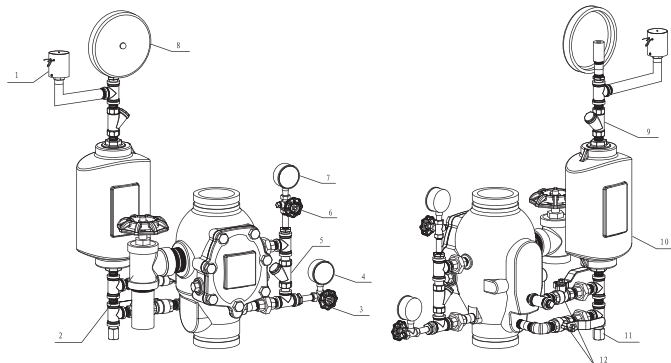

External accessories			
Part No.	Part	Part No.	Part
1	Pressure Switch	7	Pressure Gauge
2	Indoor Fire Hydrant	8	Alarm
3	Ball Valve	9	Strainer
4	Pressure Gauge	10	Decelerator
5	check Valve	11	Water Valve
6	Ball Valve	12	Ball Valve

# Hydraulic Control Valve

## • Statement

The hydraulic control valve was initially originated in Holand, Israel and Denmark, used for agricultural irrigation. Later the product was introduced into the United Sates, Canada and Asian countries. It was from the 1990s when the product first entered China, and ever since its entrance it gets rapidly developed and widely applied in different industrie aside from irrigation.

The hydraulic control valve produced by Jinan Meide is new style that absorbed the essence of other well-known brands which makes it better in energy saving, consumption reducing and accurate adjusting achieving. The MECH brand hydraulic control valves have been widely used in China, Europe and South East Asian countries in pipe system of irrigation, water supplying, fire protection and air conditioning which has medium of water under 80°C or other medium with similar physical and chemical property as water.

## • Specifications

Basic Valve: Y-Type Direct-flow  
 Connection Ends: Flange to ASME B16.1 CL 125  
 Temperature Range: 0°C- 80°C  
 Working Pressure: 300PSI  
 Testing Standard: API 598

## • Flow Diagram of Basic Valve

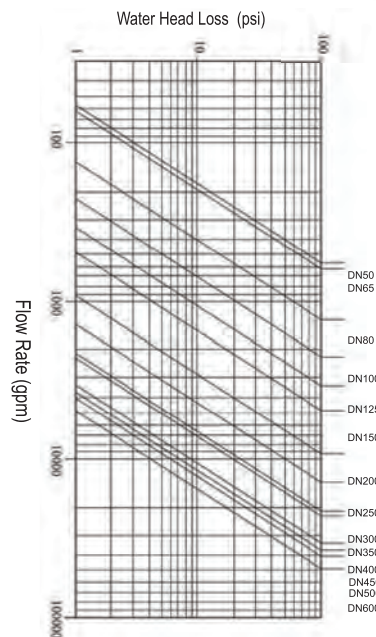
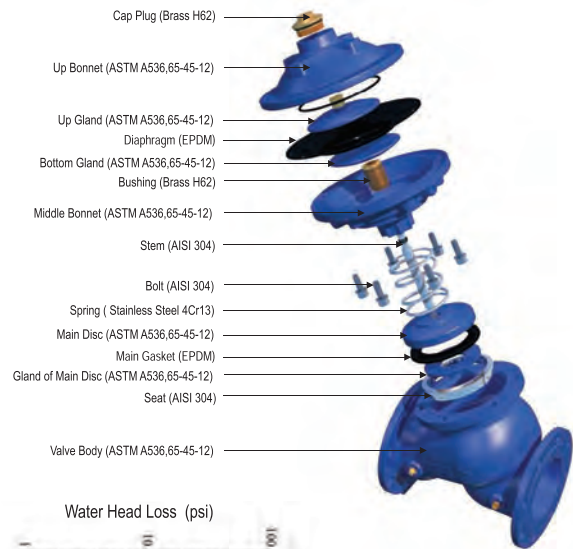
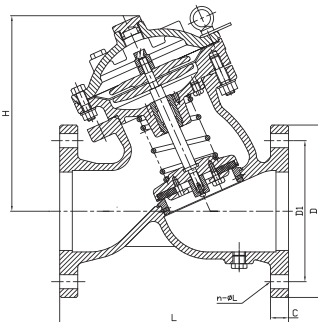

DN	50	65	80	100	125	150	200	250	300	350	400	450	500	600
Kv	41	53	105	175	285	402	730	1160	1400	1770	3010	3225	3395	4272

DN		Dimensions(mm)					
Inch	mm	L	H	D	D1	b	n-ΦL
2"	50	206	170	152	120.5	16	4-Φ19.1
2.5"	65	211	195	178	139.5	17.5	4-Φ19.1
3"	80	249	215	191	152.5	19	4-Φ19.1
4"	100	320	255	229	190.5	24	8-Φ19.1
6"	150	414	360	279	241.5	25.5	8-Φ22.2
8"	200	500	450	343	298.5	28.5	8-Φ22.2
10"	250	605	550	406	362	30.5	12-Φ25.4
12"	300	724	645	483	432	32	12-Φ25.4
14"	350	734	700	533	476	35	12-Φ28.5
16"	400	991	790	597	540	36.5	16-Φ28.5

For Fire Sprinkler System

## SK720X Pressure Reducing Valve

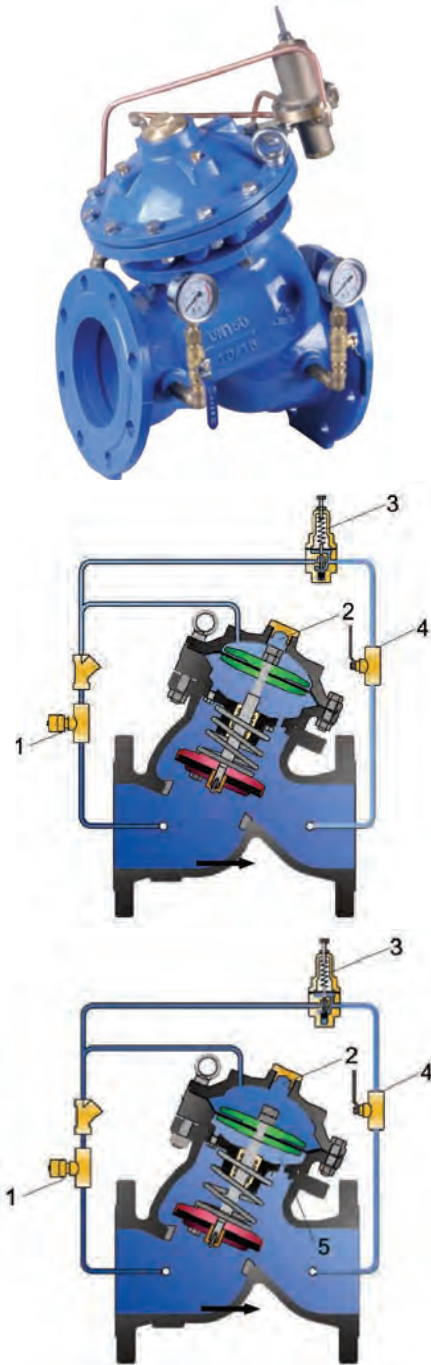

### 1.Statement

SK720X Pressure Reducing Valve is a diaphragm type of hydraulic control valve driven by the hydraulic pressure within the piping system. The function of the valve is to reduce the high pressure to the pre-set low pressure, and despite the fluctuation of medium flow or pressure before the valve the pressure after the valve will always remain stable and maintain the set pressure range.

### 2.Operational principle

SK720X Pressure Reducing Valve is controlled by pressure reducing pilot valve and equipped with pressure reducing pilot valve, needle valve, mini strainer and ball valve, etc.

Under normal conditions, water flow comes continuously from the inlet opening to the upper cavity room (2) of the basic valve through the needle valve (1); When the pressure before the pilot valve (3) is lower than its pre-set value, the pilot valve will remain at full open position and the upper cavity room of the basic valve is not able to get accumulating pressure. Under this condition, the disc of the basic valve will be open at the water pressure from the inlet opening to allow water flow. The pressure reducing pilot valve closes gradually when the pressure after pilot valve exceeds its pre-set value. Pressure gets accumulated within the upper cavity room and membrane drives the disc down to close the valve till the pressure after the pilot valve gradually reduces to its pre-set value. The pilot valve opens again when the pressure after the valve becomes lower than the pre-set value, and the basic valve will then open with the release of the accumulated pressure in the upper cavity room.

The throttle orifice (5) that connects the lower cavity to the outlet serves to keep the reaction of the valve gentle and stable. The ball valve (4) controls the outlet water flow rate from the upper cavity room and thus to stabilize the action of the basic valve. The ball valve can be adjusted with different working conditions. In case of emergency, the ball valve can also be closed manually for cutting off of the basic valve.

### 3.Property and advantages

- Driven by pressure of pipe system, work automatically with energy of pipe system to achieve energy conservation and environment protection.
- Controlled by the pilot valve, lower energy consumption, achieve accurate pressure reducing results, have function of stabilizing pressure after the valve.
- Dual cavity design, with functions of fully opening and fully closing. Slow shut causes no pressure fluctuation, and the diaphragm with support is well protected.
- Have internal orifice, connect bottom cavity and outlet of the basic valve, make sure stability of reaction to keep stability of pressure after the valve, avoid any vibration and noise.
- Channel with straight-flow, slight friction loss, no eddy flow and turbulent flow, cut down the damage of cavitation.
- Long pitch orientation design for stem move, stable and no gap resistance.
- Balanced automatically, big gap design on connection of disc and stem, disc is free on the vertical flat against stem, it can balance the tolerance from machining and sealing surface. Good connection without leakage. Achieve functions of both reducing dynamic pressure and reducing static pressure.
- Ductile iron castings with nodularity higher than 90%, foundry in house with advanced melting technology and strict quality control system, testing reports and testing bars can be supplied with order. Records and testing bars maintained for one year in the factory.
- Good corrosion resistance, with stainless steel, copper alloy, rubber made from DuPont and other rust-resisting material, fusion bonded epoxy coating both for interior and exterior surface of the basic valve. All the characteristics in accordance with ANSI/AWWA C550 and other international specifications like WRAS, NSF61.

#### 4. Typical installation illustration

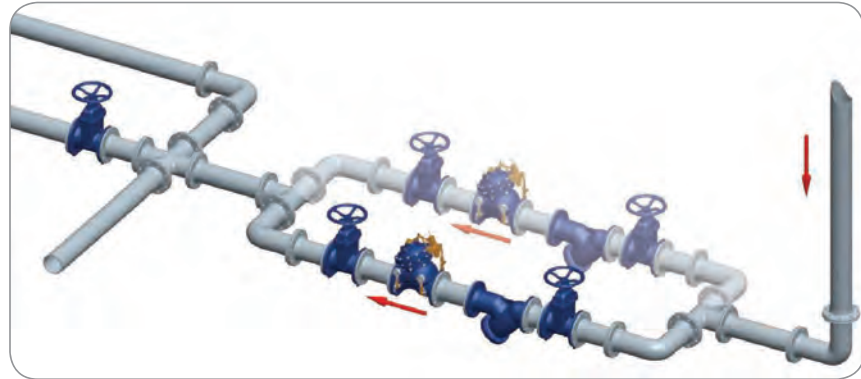

#### 5. Basic Parameters

Pressure	Symbol	Unit	Working Pressure		
			175PSI	250PSI	300PSI
Max. Inlet pressure	P1max	MPa	1.0	1.6	2.5
Min. Inlet pressure	P1min		P2max + 0.2		
Max. Outlet pressure	P2max		0.8	1.0	1.6
Min. Outlet pressure	P2min		0.05		
Characteristics of flow deviation	$\Delta P2Q$		$\leq 10\%$		
Pressure characteristic deviation	$\Delta P2p$		$\leq 5\%$		
Min. pressure deviation	$\Delta Pmin$		0.2		

#### 6. Notes for installation and debugging

All the Pressure Reducing Valves have been finished initial debugging tests before delivery. Further debugging test is also suggested during using according to different working conditions.

After the pipe system becomes stable, please loose the adjusting screw on the top of pilot valve to the top-most position.

Tighten adjusting screw of pilot valve in clockwise slowly. When outlet pressure increase to the set pressure please fasten the locknut under the adjusting screw.

If go beyond the set pressure during adjusting, please repeat the above steps. Remember, pressure can be only adjusting from low level to high level and pay attention to make the adjusting slowly.

#### 7. Common problems and proposed solutions

Common Problems	Proposed Solutions
Outlet pressure is similar with inlet pressure, no pressure reduction.	<ul style="list-style-type: none"> <li>a. Check if any sundries on the sealing surface of basic valve or pilot valve.</li> <li>b. Check if any damage on the sealing surface of basic valve or pilot valve.</li> <li>c. Check if any damage or fatigue on spring of basic valve or pilot valve.</li> <li>d. Check if any damage or fatigue on diaphragm of basic valve or pilot valve.</li> <li>e. Check if any corrosion or blocking on stem of basic valve or pilot valve.</li> </ul>
Strong vibration and noise.	<ul style="list-style-type: none"> <li>a. Close the needle valve before the basic valve and open 1/4 turns slowly. Open the big hex screw on the top of bonnet, release air. Adjust the needle valve on inlet conduit slowly until no vibration.</li> <li>b. Calculate the flow again and collect proper size of valve or add throttling set.</li> </ul>
Pressure after the valve is not stable.	<ul style="list-style-type: none"> <li>a. Check if pressure is fluctuating strongly at inlet. Try to keep it within small range.</li> <li>b. Check if required flow is too different than actual flow, recalculate flow and choose new valve with proper size.</li> </ul>

## SK730X Pressure Relief & Sustaining Valve

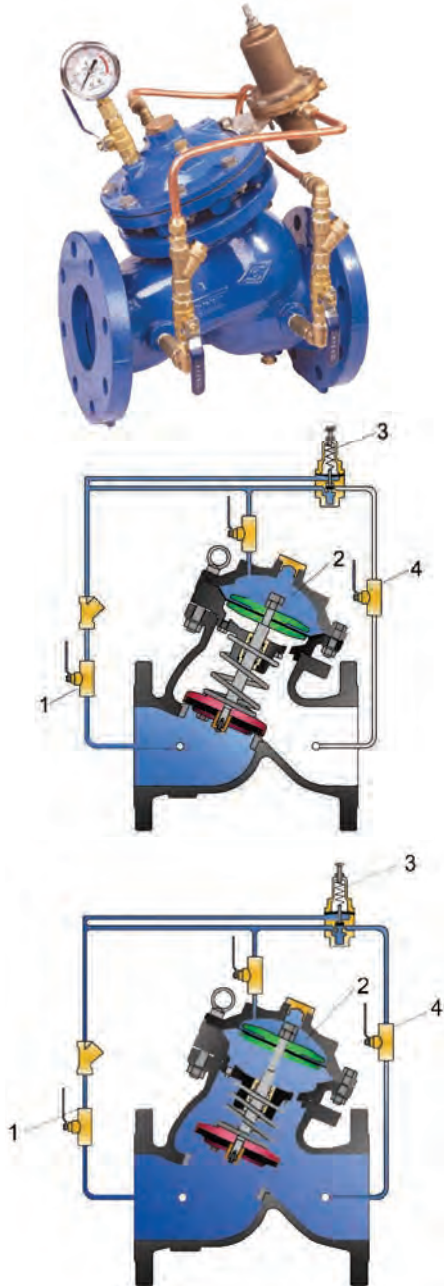

### 1.Statement

SK730X Pressure Relief & Sustaining Valve is a diaphragm type of hydraulic control valve driven by the hydraulic pressure within the piping system. One prominent feature of the valve is, it can serve as pressure relief valve and sustaining valve at the same time. As pressure relief valve, it releases the high pressure before the valve out of the piping system for protection of the pipes and the equipments when the pressure exceeds its pre-set value; As pressure sustaining valve, it maintains the water pressure above certain set value for guarantee of water supply to upstream area

### 2.Operational principle

SK730X Pressure Relief & Sustaining Valve is controlled by pressure relief/sustaining pilot valve and equipped with pressure relief/sustaining pilot valve, needle valve, mini strainer and ball valve, etc.

As Pressure relief valve, the valve is connected with branch pipe and directed to lower pressure area or drainage ditch. In normal working conditions, water flow enters the upper cavity room (2) through needle valve (1). When the pressure before the pilot valve (3) is lower than its pre-set value A, the pilot valve will remain closed and the water that enters the upper cavity room drives the membrane down and closes the disc and the basic valve. The pilot valve opens when the pressure before the valve exceeds its pre-set value and the pressure accumulated in the upper cavity room gets released. Under the pressure from the inlet opening, the disc of the basic valve opens. In this way the pressure within the piping system will be maintained under the pre-set value A.

As pressure sustaining valve, the valve is connected in series with the main pipe and serves to maintain the pressure before valve above the set value B. Under normal conditions, water flow comes continuously from the inlet opening to the upper cavity room (2) of the basic valve through the needle valve (1); When the pressure before the pilot valve (3) is lower than its pre-set value, the pilot valve will remain closed and the water that enters the upper cavity room drives the membrane down and closes the disc and the basic valve for accumulation of pressure till equals to the set value B. The pilot valve opens when the pressure before the valve exceeds its pre-set value and the pressure accumulated in the upper cavity room gets released. Under the pressure from the inlet opening, the disc of the basic valve opens to allow water flow. In this way the pressure within the piping system will be maintained under the pre-set value B.

### 3.Property and advantages

- Driven by pressure of pipe system, work automatically with energy of pipe system to achieve energy conservation and environment protection.
- Controlled by pilot valve, lower energy consumption, achieve accurate pressure relief and pressure holding results, reliable and safe.
- Dual cavity design, with functions of fully opening and fully closing. Slow shut causes no pressure fluctuation, and the diaphragm with support is well protected.
- Have internal orifice, connect bottom cavity and outlet of the basic valve, make sure stability of reaction to keep stability of pressure after the valve, avoid any vibration and noise.
- Channel with straight-flow, slight friction loss, no eddy flow and turbulent flow, cut down the damage of cavitation.
- Long pitch orientation design for stem move, stable and no gap resistance.
- Balanced automatically, big gap design on connection of disc and stem, disc is free on the vertical flat against stem, it can balance the tolerance from machining and sealing surface. Good connection without leakage.
- Ductile iron castings with nodularity higher than 90%, foundry in house with advanced melting technology and strict quality control system, testing reports and testing bars can be supplied with order. Records and testing bars maintained for one year in the factory.
- Good corrosion resistance, with stainless steel, copper alloy, rubber made from DuPont and other rust-resisting material, fusion bonded epoxy coating both for interior and exterior surface of the basic valve. All the characteristics in accordance with ANSI/AWWA C550 and other international specifications like WRAS, NSF61.



#### 4. Typical installation illustration

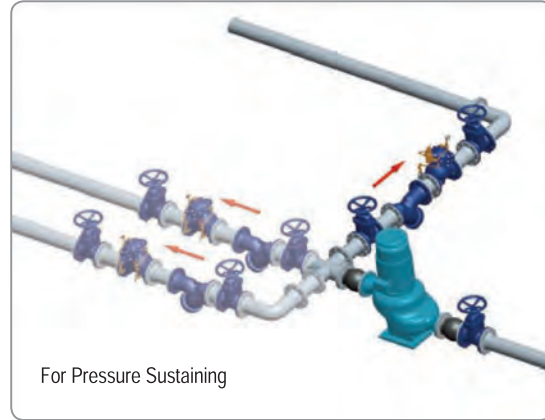
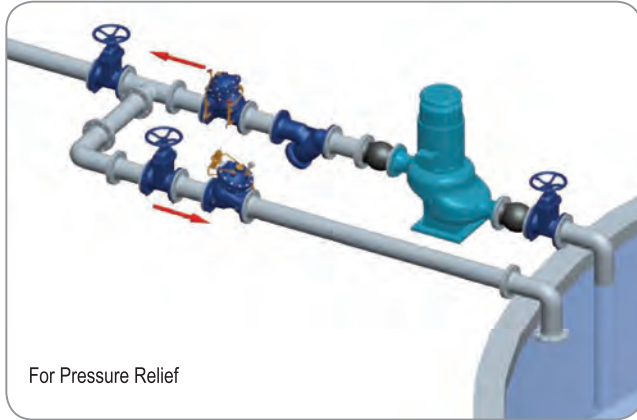

#### 5. Basic Parameters

Pressure	Symbol	Unit	Working Pressure		
			175PSI	250PSI	300PSI
Set Pressure	Ps	MPa	≤0.83	≤1.33	≤1.7
Set Pressure Difference			Ps < 0.5: ±0.014 MPa; Ps ≥ 0.5: ±3%Ps		
Open/Close Pressure Difference	ΔPb		Ps < 0.3: 0.06MPa; Ps ≥ 0.3: 20%Ps		
Discharge pressure	Pd		≤1.2Ps		

#### 6. Notes for installation and debugging

All the Pressure Relief & Sustaining Valves have been finished initial debugging tests before delivery and the set-pressure is 0.6MPa. Further debugging test is also suggested during using according to different working conditions.

After the pipe system becomes stable, please loose the lock nut under adjusting screw, open the ball valve or needle valve (1) slightly, when pressurize, adjust the adjust screw on pressure relief pilot valve and fasten the lock nut when it achieves pressure required. Pay attention that when adjust pressure relief pilot valve, clockwise is for increasing pressure and anti-clockwise is for reducing pressure.

#### 7. Common problems and proposed solutions

Common Problems	Proposed Solutions
The pressure of pipe system is lower than set-pressure, the valve dose not close.	a. Check if any sundries on the sealing surface of basic valve or pilot valve. b. Check if any damage on the sealing surface of basic valve or pilot valve. c. Check if any damage or fatigue on spring of basic valve or pilot valve. d. Check if any damage or fatigue on diaphragm of basic valve or pilot valve.
The pressure of pipe system is higher than set-pressure, the valve dose not open.	a. Check if ball valve (4) is closed, if yes, please open it. b. Check if any blocks in basic valve or on stem of pilot valve, if yes, please remove the block or change new stem. c. Check if lock nut and adjust screw were adjusted wrongly, please try to repeat all the actions.

## SK790X Deluge Alarm Valve

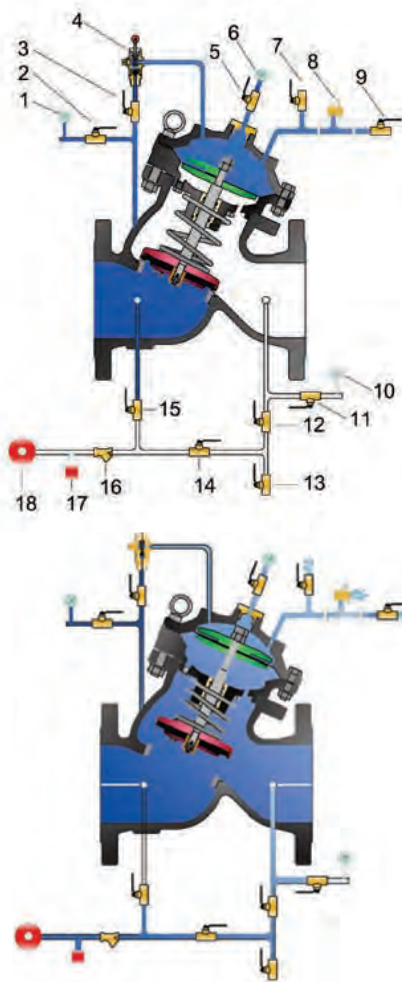

### 1.Statement

SK790X Deluge Alarm Valve is a diaphragm type of hydraulic control valve driven by the hydraulic pressure within the piping system, functioning as flow control and alarming device in the sprinkler and pre-action system, i.e. to start the sprinkler system for quenching of the fire and send out fire alarm through the fire bell when there is fire detected.

### 2.Operational principle

SK790X Deluge Alarm Valve is equipped with solenoid, anti-reset controller, mini strainer, ball valve and pressure gauge, etc..

For deluge valve there is set condition and work condition. When the valve is under set condition, ball valve (3) is open, ball valve (7), solenoid (8) and remote ball valve (9) are closed, the anti-reset controller is connected, and pressure gauge (1) and pressure gauge (6) shows the same value. When ball valve (11) is open, pressure gauge (10) shows 0. When ball valve (12) and (14) are open, (13) & (15) closed, there is no hydraulic pressure for pressure switch (17), and alarm (18) does not work. Under set condition, you can operate as following if you want to test the pressure switch alarm device (17) and water motor alarm (18): close ball valve (14) and open (15), and then close (15) and open (14) after testing.

In case there is fire detected, the following 3 methods will set the deluge valve into work condition immediately, A: Opening solenoid valve (8) B: Opening ball valve (7) C: Opening remote ball valve (9). Any of the above 3 methods can get the pressure within the control room of the basic valve released rapidly to open the valve and set it into working condition. At this time the sealing ball of anti-reset controller makes controller in a shutdown state, water will pass through the main valve, ball valve (12), (4), pressure switch (17), fire bell (18), the pressure switch bell sends out signal alarms. After fire fighting, close ball valve (7), solenoid valve (8), remote valve (9), press the anti-reset controller handle till the pressure gauge (6) and pressure gauge (1) shows the same value. The deluge alarm valves returns to set condition.

Ball valve (2), (5) & (11) are normally open unless need to change the pressure gauge.

### 3.Property and advantages

- Driven by pressure of pipe system, work automatically with energy of pipe system to achieve energy conservation and environment protection.
- Dual cavity design, with functions of fully opening and fully closing. Slow shut causes no pressure fluctuation, and the diaphragm with support is well protected.
- Triple insurance, there're three opening types used for different situation of firing. Anyone can make the valve into working condition.
- Anti-reset controller, hydraulic pressure type, compact design, tight sealing, operating by hand to make sure all the parts including basic valve, ball valves and conduits are all in good condition after out-fire.
- Channel with straight-flow, slight friction loss, no eddy flow and turbulent flow, cut down the damage of cavitation.
- Long pitch orientation design for stem move, stable and no gap resistance.
- Balanced automatically, big gap design on connection of disc and stem, disc is free on the vertical flat against stem, it can balance the tolerance from machining and sealing surface. Good connection without leakage. Achieve functions of both reducing dynamic pressure and reducing static pressure.
- Ductile iron castings with nodularity higher than 90%, foundry in house with advanced melting technology and strict quality control system, testing reports and testing bars can be supplied with order. Records and testing bars maintained for one year in the factory.
- Good corrosion resistance, with stainless steel, copper alloy, rubber made from DuPont and other rust-resisting material, fusion bonded epoxy coating both for interior and exterior surface of the basic valve. All the characteristics in accordance with ANSI/AWWA C550 and other international specifications like WRAS, NSF61.

#### 4. Typical installation illustration

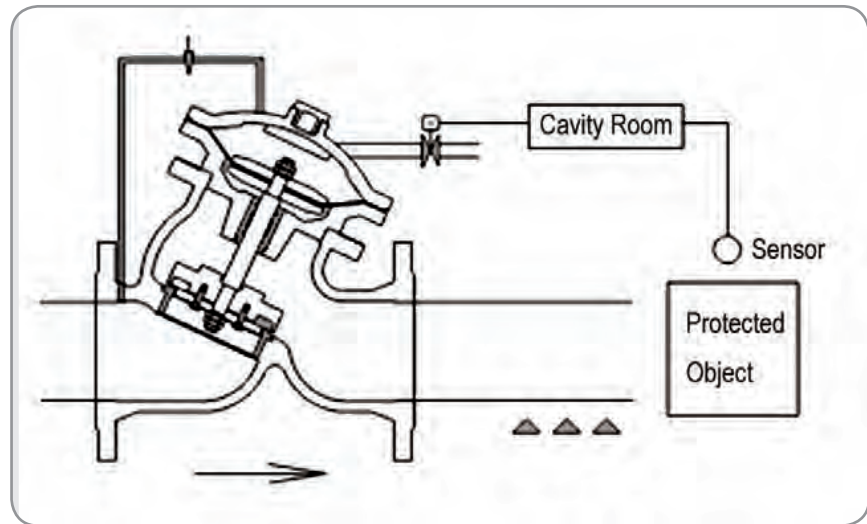

#### 5. Notes for installation and debugging

Please check if pressure switch and alarm bell are in good condition before installation. Make sure water can not leak to system from water supplying system or there's equipment to discharge the leaked water.

Please adjust all the ball valves to make sure the basic valve be in set condition.

Make sure anti-reset controller is in good condition and seal well before installation. If there's water with pressure in front of the valve, please closed ball valve (7), (9) and electromagnetic valve when it's in empty state behind the basic valve, press the anti-reset controller, when up cavity of basic valve is full of water please check if there's any leakage behind the valve. If no leakage, it said anti-reset controller is in good condition.

#### 6. Common problems and proposed solutions

Common Problems	Proposed Solutions
Press anti-reset controller after fire-out, there's still water coming out behind the valve.	<ul style="list-style-type: none"> <li>a. Check if any sundries or damage on the sealing surface of basic valve or anti-reset controller.</li> <li>b. Check if any damage on diaphragm.</li> <li>c. Check if controlling valve (7), (8) and (9) were closed completely. Close them or replace with new ones.</li> </ul>
When open controlling valve (7), (8) and (9) no water comes out from the basic valve.	<ul style="list-style-type: none"> <li>a. Check if controlling valve (7), (8) and (9) were opened. Close them or replace with new ones.</li> <li>b. Check if there's block on stem of basic valve, repair it.</li> </ul>



مؤسسة مستقبل الميكانيكا للتجارة  
Future Mechanics Trading Est.

P.O. Box 28027-Riyadh 11437 - Kingdom of Saudi Arabia

Tel.: +966 11 478 4242 - Fax: +966 11 472 9595

[www.meide-casting.com](http://www.meide-casting.com)